

INJ. PUMP CALIBRATION DATA

ENGINE MODEL ED30

BOSCH No. 9 400 610 114 1/4
 DKKC No. 101431 - 0620
 Date : 28, Feb. 1990 [2]
 Company : ISUZU
 No. 515601-0292

B - 1

101431 - 0620 2/4

Injection pump : PES4A Governor : EP/RBD Timing device : EP/SCD
 101043-9160 105542-6700 105621-0370

1. Test Conditions :

Pump rotation : clockwise viewed from drive side

Nozzle & Nozzle Holder Ass'y : 105780-0000 (BOSCH Type No. DN12SD12T)
 Nozzle Holder : 105780-2080 (BOSCH Type No. EF8511/9A)
 Nozzle opening pressure : 175 kg/cm² Transfer pump pressure : 1.6 kg/cm²

Injection pipe : Inner Dia. 2 mm x Outer Dia. 6 mm — Length 600 mm

Test Oil : ISO4113 or SAE Standard Test Oil (SAE J967d) Oil Temp. : 40°C

Overflow valve opening pressure : kg/cm²

2. Injection Timing :

Pre-stroke : No. 1 Plunger 2.25 ± 0.05 mm

Note : Adjust with control rod position of mm

Injection order : 1 - 3 - 4 - 2 - 1 (interval : 90° ± 30')

Plungers are numbered from the Drive side.

Tappet clearance : Bolt adjustment type : More than 0.3 mm for all cylinders.
 : Shim adjustment type : Manually rotate the camshaft 2 - 3 times and confirm that it rotates smoothly.

4. Injection Quantity :

Adjusting Point	Rod Position (mm)	Pump Speed (r.p.m.)	Injection Q'ty (cc/1000 strokes)	Max. var bet. cyl (%)	Fixed	Remarks
A	11	1,450	36.7 ~ 38.7	± 2.5	Rack	Basic
B	11	750	29.3 ~ 32.1	± 4.5	Rack	
C	11.7	750	33 ~ 36.4	± 4.5	Rack	
D	Approx. 7.4	300	6.9 ~ 9.1	± 14	Rack	

5. Timing Advance Specification :

Pump Speed (r.p.m)	450 ~ 550	800	1,050	1,500	1,750		
Advance Angle (deg)	Start	0.5 ~ 1.5	1.2 ~ 2.7	3.9 ~ 4.9	5.5 ~ 6.5		

3. GOVERNOR ADJUSTMENT

(1) Pneumatic Governor

(2) Mechanical Governor

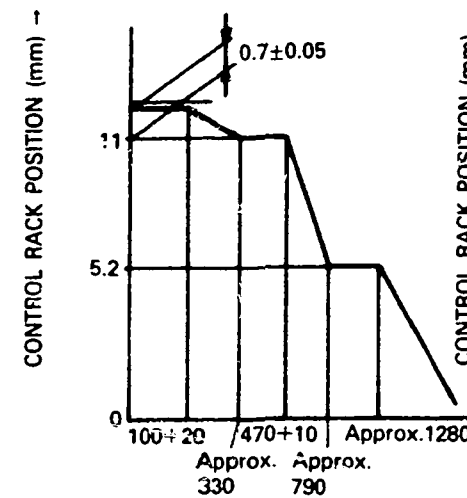

NEGATIVE PRESS. (mmAq) —

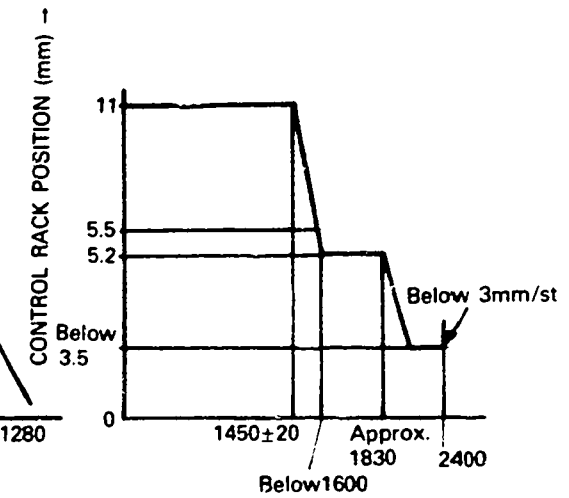

PUMP SPEED (rpm) —

■ Air Tightness Test

1. Increase the pressure of the pneumatic governor's negative pressure chamber to 470 mmAq at a pump speed of 470 rpm and a control rack position of Approx. 11.7 mm.
2. Then, confirm that it takes 10 seconds or more for the negative pressure to fall from 480 mmAq to 460 mmAq.

■ Adjustment

1. Pneumatic Governor (Pump Speed: 470 rpm)

Item	Negative Press. (mmAq)	Rack Position (mm)	Remarks
Smoke Set Screw Adjustment	0	11.7	• Adjust using spring capsule ①.
Torque Control Adjustment	100 ~ 120	11.7	• Adjust thickness of shim ①.
	Approx. 330	11	• Adjust thickness of shim ②.
	—	—	③ Confirm
	—	—	④ Confirm torque control stroke



DIESEL KIKI CO., LTD. 3-6-7 SHIBUYA, SHIBUYA-KU, TOKYO 150, JAPAN
 Service Department Tel. (03)5485-4135 Fax: (03)5485-4115

Item	Negative Press. (mmAq)	Rack Position (mm)	Remarks
High-speed Control Adjustment	460 ~ 480	11	• Adjust thickness of shim ③.
Idling Adjustment	Approx. 790 Approx. 1,280	5.2 5.2	• Adjust using spring capsule ②. • Confirm

2. Mechanical Governor (Negative pressure: 460 ~ 480 mmAq)

Item	Pump Speed (rpm)	Rack Position (mm)	Remarks
Maximum Speed Control Adjustment	1,430 ~ 1,470	11	• Adjust using screw ①.
	Approx. 1,830 Approx. 2,400	5.2 Below 3.5	• Confirm • Confirm (Check the fuel injection quantity: below 3 cc/1000st)

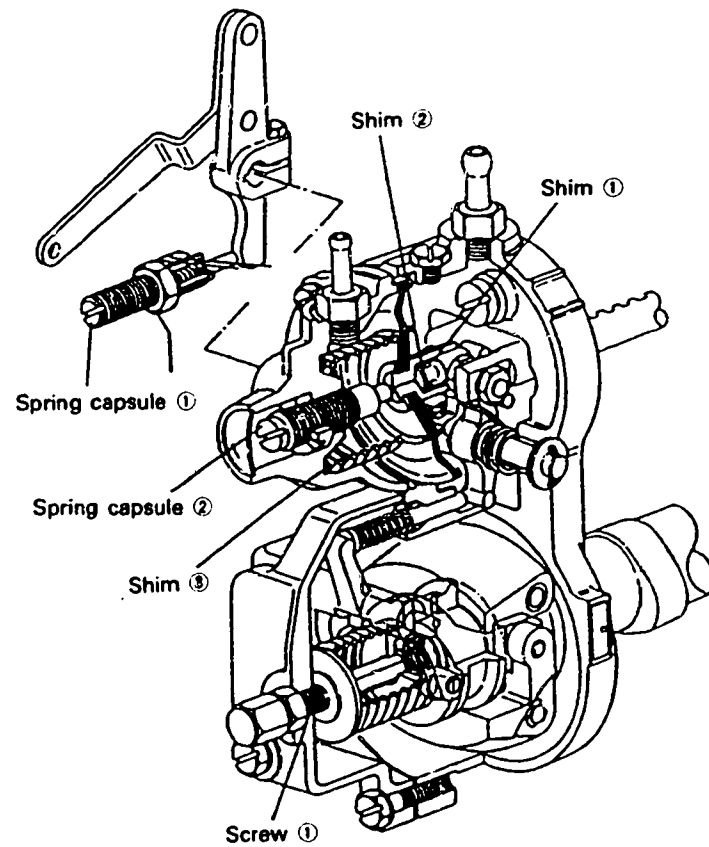

■ Final Adjustment

Smoke Setting			Fuel Injection Quantity Adjustment		
Pump Speed (rpm)	Negative Press. (mmAq)	Injection Q'ty (cc/1000st)	Pump Speed (rpm)	Negative Press. (mmAq)	Injection Q'ty (cc/1000st)
1450	11	36.7 ~ 38.7			

■ Timing Setting

At No. 4 plunger's beginning of injection position.
B.T.D.C.: 14°

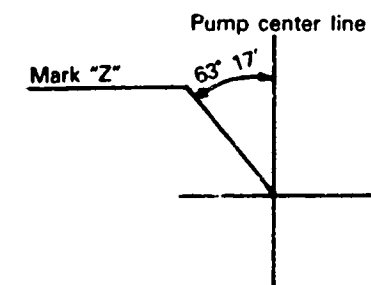

INJ. PUMP CALIBRATION DATA

ENGINE MODEL 6BD1

BOSCH No. 9 400 610 106 1/4
 DKKC No. 101602 - 0640
 Date : 28, Feb. 1990 [4]
 Company : ISUZU
 No. 115600 9373

B - 3

101602-0640 2/4

Injection pump : PES6A Governor : EP/RSV Timing device :
 101060-8440 105410-3510

1. Test Conditions :

Pump rotation : Counter clockwiseviewed from drive side

Nozzle & Nozzle Holder Ass'y : 105780-0000 Nozzle Holder : 105780-2080
 (BOSCH Type No. DN12SD12T) (BOSCH Type No. EF8511/9A)
 Nozzle opening pressure : 175 kg/cm² Transfer pump pressure : 1.6 kg/cm²
 Injection pipe :
 Inner Dia. 2 mm x Outer Dia. 6 mm - Length 600 mm

Test Oil : ISO4113 or SAE Standard Test Oil (SAE J967d) Oil Temp. : 40±5°C

Overflow valve opening pressure : - kg/cm²

2. Injection Timing :

Pre-stroke : No. 1 Plunger 3.6 ± 0.05 mm

Note : Adjust with control rod position of mm

Injection order : 1 - 5 - 3 - 6 - 2 - 4 (interval : 60° ± 30')

Plungers are numbered from the Drive side.

Tappet clearance : Bolt adjustment type ; More than 0.3 mm for all cylinders.
 : Shim adjustment type ; Manually rotate the camshaft 2 ~ 3 times and confirm that it rotates smoothly.

4. Injection Quantity :

Adjusting Point	Rod Position (mm)	Pump Speed (r.p.m.)	Injection Q'ty (cc/1000 strokes)	Max. var bet. cyl (%)	Fix. J	Remarks
A	9.4	800	66.3 - 68.3	± 2	Lever	Basic
B	8.7	1,100	56.9 - 60.9	± 4	Lever	
C	Approx. 6.5	385	8.1 - 10.7	± 14	Rack	

5. Timing Advance Specification :

Pump Speed (r.p.m.)							
Advance Angle (deg)							

3. GOVERNOR ADJUSTMENT

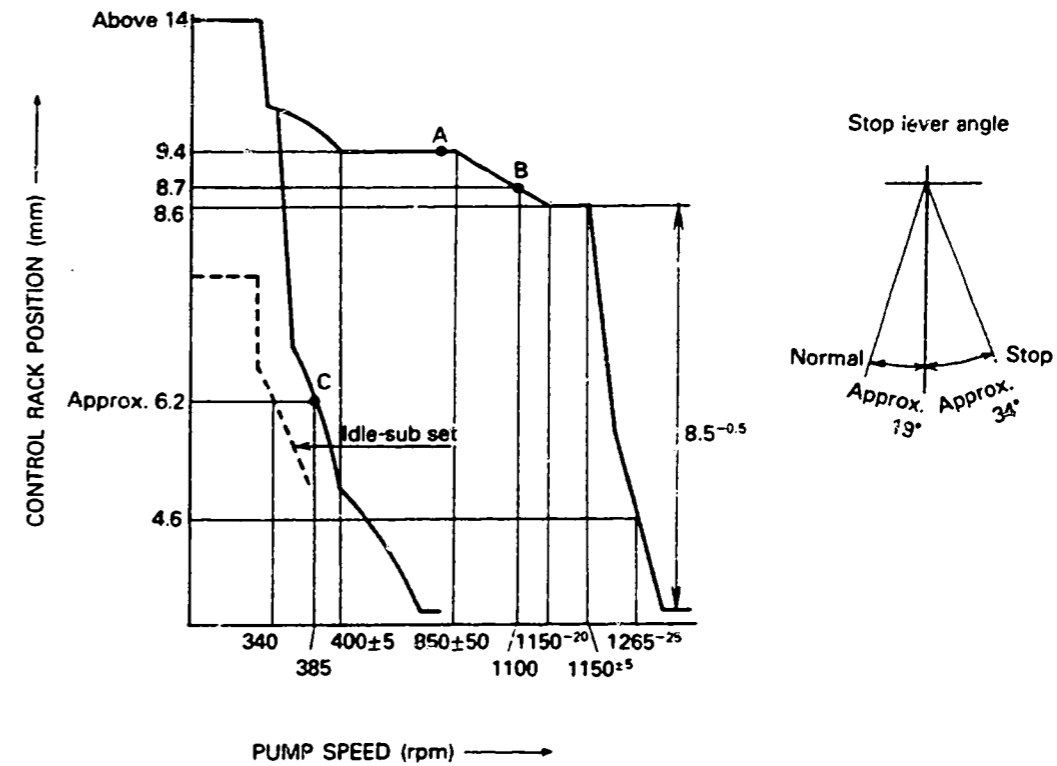

■ Note

- Before adjustment, remove the idling sub spring and the torque control spring.
- Move the control lever fully in the stop direction, and set the minimum-speed stopper bolt so that the control rack position is 0.5 ~ 1.0 mm.

■ Adjustment

Item	Pump Speed (rpm)	Rack Position (mm)	Remarks
Full-load Adjustment (Temporary)	1145 ~ 1155	8.6	• Adjust using screw ①
	1140	8.6	• Adjust using screw ②
Torque Control Spring Adjustment	800	9.4	• Adjust using spring capsule ①
	800 ~ 900	9.4	• Confirm
	1100	8.7	• Confirm
	1130 ~ 1170	8.6	• Confirm the torque control stroke is 0.6 mm.

Item	Pump Speed (rpm)	Rack Position (mm)	Remarks
Idling Adjustment	385 0 340 —	Approx. 6.2 — Approx. 6.2 —	<ul style="list-style-type: none"> • Fix the control lever • Freely position the control lever • Adjust using spring capsule ② • Confirm
Maximum-speed Adjustment	1145 ~ 1155 1240 ~ 1265 1300	8.6 4.6 0.1 ~ 0.6	<ul style="list-style-type: none"> • Adjust using screw ① • Confirm speed droop • Confirm • Confirm
Full-load Adjustment (Install the cover on governor cover)	800	9.4	<ul style="list-style-type: none"> • Adjust using screw ③
Control Lever Angle Measurement	<ul style="list-style-type: none"> • Measure the control lever angle at the "idling" and "full" positions. • When the control lever is depressed toward the "full" position, replace the shifter's shim with a thicker one. • When the control lever is depressed toward the "idling" position, replace the shifter's shim with a thinner one. 		
Rack Limiter Adjustment	—	—	<ul style="list-style-type: none"> • Adjust using screw

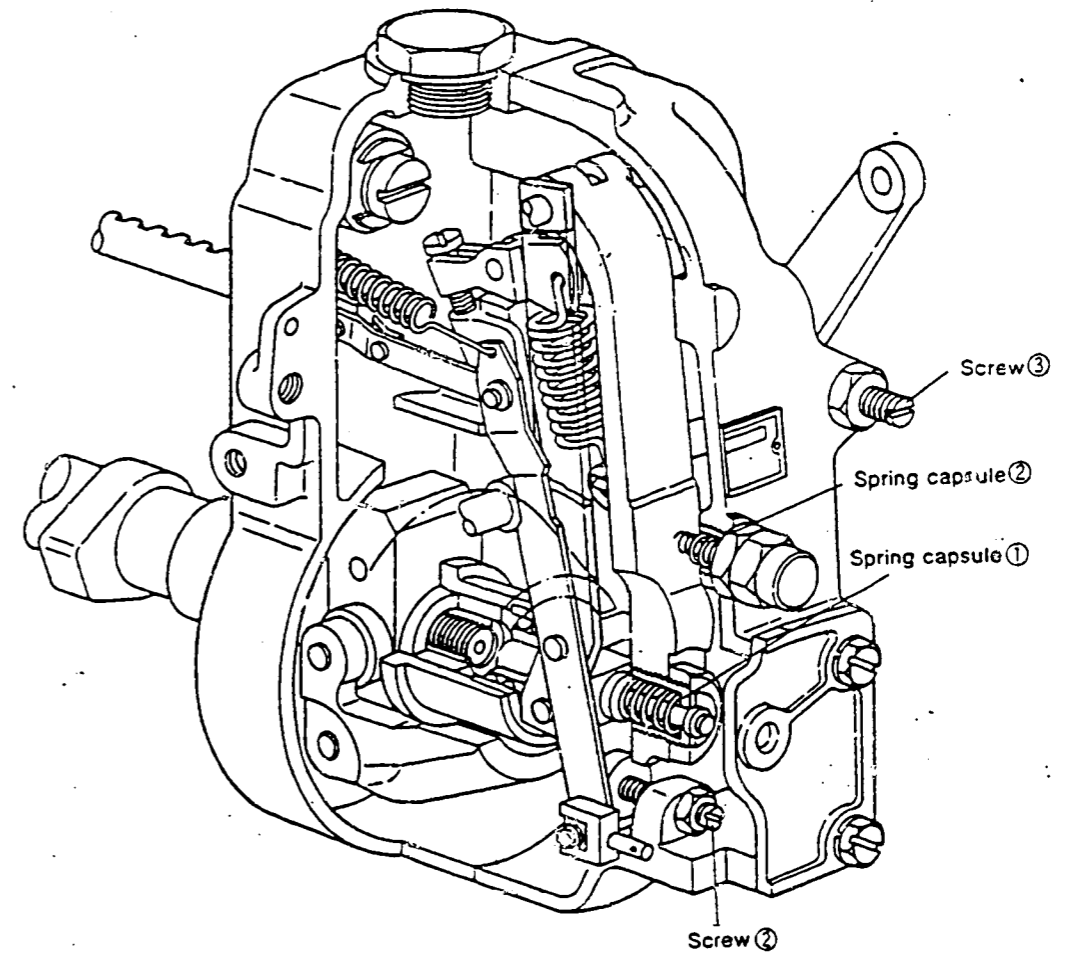

INJ. PUMP CALIBRATION DATA

ENGINE MODEL SD33

BOSCH No. 9 400 610 108 1/4
 DKKC No. 101631 - 9280
 Date : 28, Feb. 1990 ②
 Company : NISSAN DIESEL
 No. 15790 90105

B - 5

101631 - 9280 2/4

Injection pump : PES6A Governor : EP/R5V Timing device : EP/SCD
 101063-9250 105412-1510 105622-0250

1. Test Conditions :

Pump rotation : clockwise viewed from drive side

Nozzle & Nozzle Holder Ass'y : 105780-0000 Nozzle Holder : 105780-2080
 (BOSCH Type No. DN12SD12T) (BOSCH Type No. EF8511/9A)
 Nozzle opening pressure : 175 kg/cm² Transfer pump pressure : 1.6 kg/cm²
 Injection pipe :

Inner Dia. 2 mm x Outer Dia. 6 mm — Length 600 mm

Test Oil : ISO4113 or SAE Standard Test Oil (SAE J967d) Oil Temp. : 40°C

Overflow valve opening pressure : kg/cm²

2. Injection Timing :

Pre-stroke : No. 1 Plunger 2.3 ± 0.05 mm

Note : Adjust with control rod position of mm

Injection order : 1 - 4 - 2 - 6 - 3 - 5

(interval : 60° ± 30')

Plungers are numbered from the Drive side.

Tappet clearance : Bolt adjustment type ; Move than 0.3 mm for all cylinders.
 : Shim adjustment type ; Manually rotate the camshaft 2 - 3 times and confirm that it rotates smoothly.

4. Injection Quantity :

Adjusting Point	Rod Position (mm)	Pump Speed (r.p.m.)	Injection Q'ty (cc/1000 strokes)	Max. var bet. cyl (%)	Fixed	Remarks
A	14.5	600	32.3 - 34.3	± 2.5	Rack	Basic
B	13.8	1,550	34.0 - 37.0	± 4	Rack	
C	Approx. 10.7	300	6.4 - 8.6	± 15	Rack	

5. Timing Advance Specification :

Pump Speed (r.p.m.)	450 - 550	700	1,100	1,500	1,800		
Advance Angle (deg)	START	0.5 - 1.5	2 - 3.5	4.5 - 5.5	7.0 - 8.0		

3. GOVERNOR ADJUSTMENT

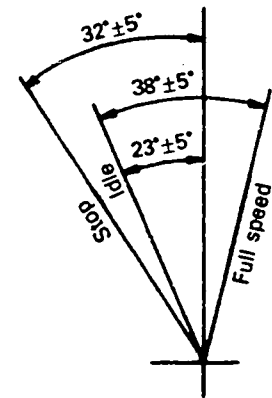
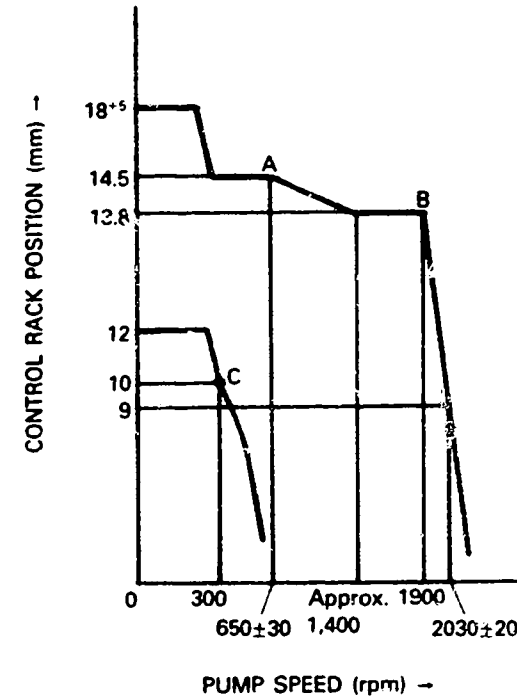

Note

- Before adjustment, remove the idling sub spring and the torque control spring.
- Move the control lever fully in the stop direction, and set the minimum-speed stopper bolt so that the control rack position is 0.5 - 1.0 mm.

Adjustment

Item	Pump Speed (rpm)	Rack Position (mm)	Remarks
Full-load Adjustment (Temporary)	1,900	13.8	• Adjust using screw ①
	1,400	13.8	• Adjust using screw ②
Torque Control Spring Adjustment	300	14.5	• Adjust using spring capsule ①
	Approx. 350	14.5	• Confirm
	Approx. 1,400	13.8	• Confirm • Confirm the torque control stroke is 0.6 - 0.7 mm.

Einstell Artikel	Pumpen drehzahl (U/min)	Regelweg (mm)	Bemerkung
Leerlauf einstellen	0 300 —	12 10 —	<ul style="list-style-type: none"> • Schraube ① einstellen • Federkapsel ② einstellen • Bestätigung
Enddrehzahl- anschlagschraube einstellen	1,900 2,010 - 2,050	13,8 9	<ul style="list-style-type: none"> • Schraube ③ einstellen • Proportionalgrad bestätigung • Bestätigung • Bestätigung
Vollast position einstellen. (Angebaute mit Verschlußdeckel)	1,900	13,8	<ul style="list-style-type: none"> • Schraube ② einstellen
Bestätigung des Verstell- hebelswinkel	<ul style="list-style-type: none"> • Bestätigen Sie der Verstellhebelswinkel auf Leerlauf und Vollast position. • Wenn der Vollastdrehzahl-Hebelwinkel außer werte ist, Verstellbolzen der Ausgleichscheibe ändern, und nochmals einstellen. • Wenn der Leerlauf-Hebelwinkel außer werte ist, Verstellbolzen der Ausgleichscheibe ändern, und nochmals einstellen. 		

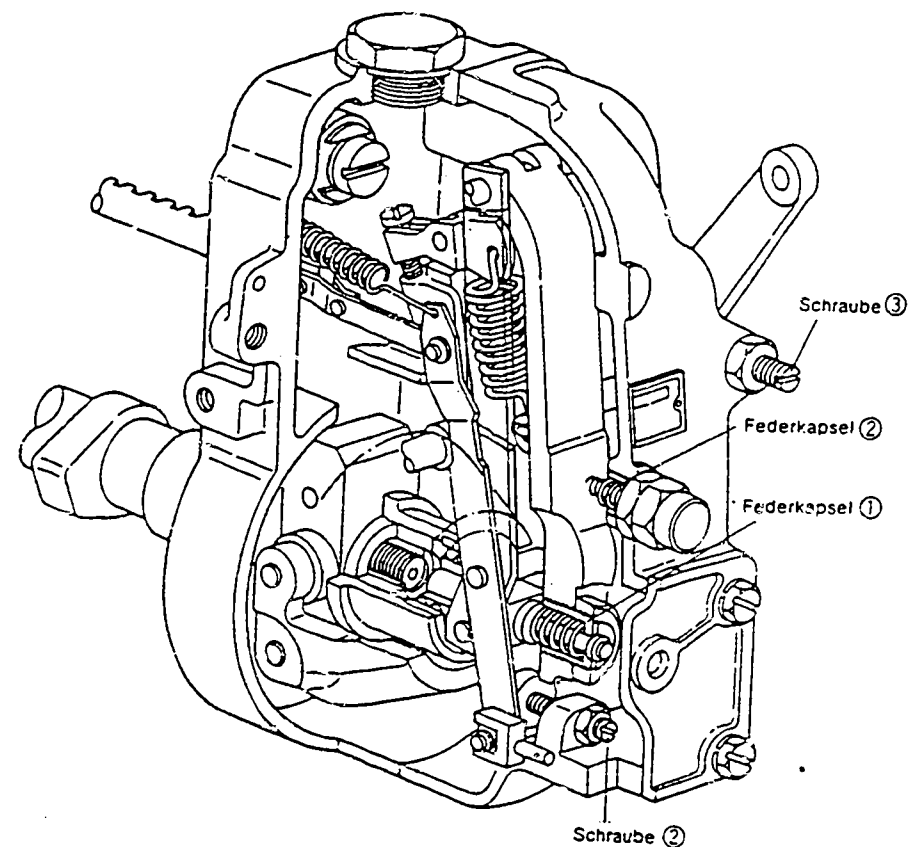

INJ. PUMP CALIBRATION DATA

ENGINE MODEL DK20T

BOSCH No. 9 400 610 102 1/4
 DKKC No. 101692 - 2540
 Date : 28, Feb. 1990 [7]
 Company : HINO
 No. 6061113111

B - 7

101692-2540 2/4

Injection pump : PE6A Governor : EP/RSV Timing device :
 101069-0821 105402-0760

1. Test Conditions :

Pump rotation : clockwise viewed from drive side

Nozzle & Nozzle Holder Ass'y : 105780-0500 Nozzle Holder : 105780-2030
 (BOSCH Type No. DN12SD12T) (BOSCH Type No. EF8511/9A)
 Nozzle opening pressure : 175 kg/cm² Transfer pump pressure : 1.6 kg/cm²

Injection pipe :
 Inner Dia. 2 mm x Outer Dia. 6 mm — Length 600 mm

Test Oil : ISO4113 or SAE Standard Test Oil (SAE J967d) Oil Temp. : 40±3°C

Overflow valve opening pressure : — kg/cm²

2. Injection Timing :

Pre-stroke : No. 1 Plunger 2.1 ± 0.05 mm

Note : Adjust with control rod position of mm

Injection order : 1 - 4 - 2 - 6 - 3 - 5 (interval : 60° ± 30')

Plungers are numbered from the Drive side.

Tappet clearance : Bolt adjustment type ; More than 0.3 mm for all cylinders.
 : Shim adjustment type ; Manually rotate the camshaft 2 ~ 3 times and confirm that it rotates smoothly.

4. Injection Quantity :

Adjusting Point	Rod Position (mm)	Pump Speed (r.p.m.)	Injection Q'ty (cc/1000 strokes)	Max. var bet. cyl (%)	Fixed	Remarks
A	15.5	800	138.7 ~ 144.7	± 2	Lever	Basic
B	15.5	500	134.7 ~ 143.7	± 3	Lever	
C	Approx. 6.4	250	10.9 ~ 15.9	± 13	Rack	
D	13.3	900	116.2 ~ 126.2	± 4	Rack	

5. Timing Advance Specification :

Pump Speed (r.p.m.)							
Advance Angle (deg)							

3. GOVERNOR ADJUSTMENT

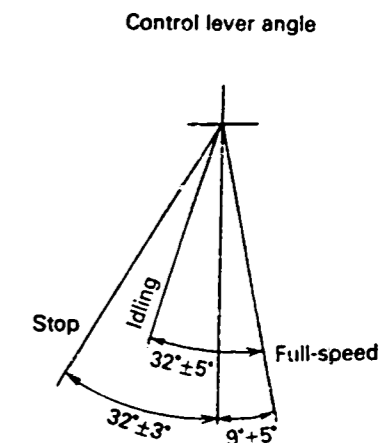
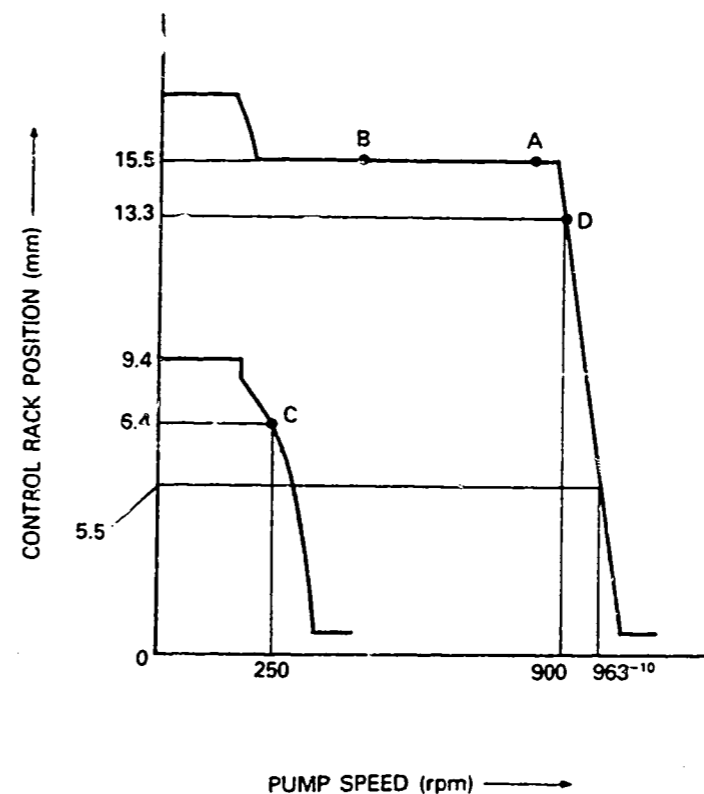

Note

- Before adjustment, remove the idling sub spring and the torque control spring.
- Move the control lever fully in the stop direction, and set the minimum-speed stopper bolt so that the control rack position is 0.5 ~ 1.0 mm.

Adjustment

Item	Pump Speed (rpm)	Rack Position (mm)	Remarks
Full-load Adjustment (Temporary)	900	13.3	• Adjust using screw ①
	800	15.5	• Adjust using screw ②
Torque Control Spring Adjustment			• Adjust using spring capsule ① • Confirm • Confirm • Confirm the torque control stroke is mm.



DIESEL KIKI CO. LTD. 3-6-7 SHIBUYA, SHIBUYA-KU, TOKYO 150, JAPAN
 Service Department Tel. (03) 400-1551 Fax: (03) 499-4115

Item	Pump Speed (rpm)	Rack Position (mm)	Remarks
Idling Adjustment	0	9.4	<ul style="list-style-type: none"> • Fix the control lever • Adjust using spring capsule ② • Confirm
	250	6.4	
	—	—	
Maximum-speed Adjustment	900	13.3	<ul style="list-style-type: none"> • Adjust using screw ① • Confirm speed droop • Confirm • Confirm
	953 - 963	5.5	
	—	—	
Full-load Adjustment (Install the cover on governor cover)	800	15.5	<ul style="list-style-type: none"> • Adjust using screw ③
Control Lever Angle Measurement	<ul style="list-style-type: none"> • Measure the control lever angle at the "idling" and "full" positions. • When the control lever is depressed toward the "full" position, replace the shifter's shim with a thicker one. • When the control lever is depressed toward the "idling" position, replace the shifter's shim with a thinner one. 		
Rack Limiter Adjustment	—	—	<ul style="list-style-type: none"> • Adjust using screw

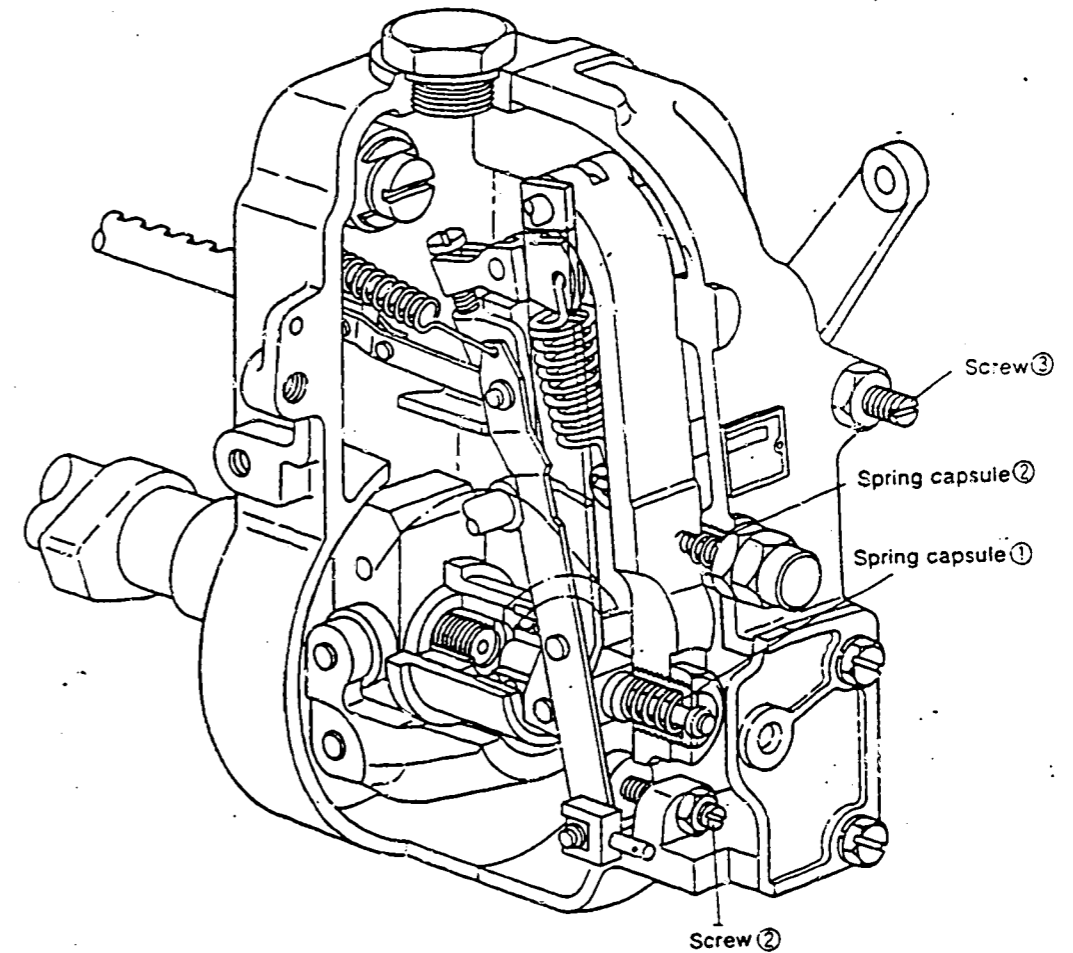

INJ. PUMP CALIBRATION DATA

TEST OIL:
ISO 4113 or
SAE J967d

ENGINE MODEL : H843 - UF

BOSCH No. 9 400 610 112 1/3
DKKC No. 104303 - 2511
Date : 28, Feb. 1990 [2]
Company : ISHIKAWAJIMA
No. 13101 7091

B - 9

104303 - 2511 2/3

Injection pump : PES3K Governor : Timing device :
104300-3851

1. Test Conditions :

Pump rotation : clockwise-viewed from drive side

Nozzle : 105720-0000 Nozzle Holder : 105780-2080
(BOSCH Type No. DN12SD12T) (BOSCH Type No. EF8511/9A)
Nozzle opening pressure : 175 kg/cm² Transfer pump pressure : 1.6 kg/cm²

Injection pipe :
Inner Dia. 2 mm x Outer Dia. 6 mm - Length 600 mm

Test Oil : ISO4113 or SAE Standard Test Oil (SAE J967d) Oil Temp. : 40±5°C

Overflow valve opening pressure : - kg/cm²

2. Injection Timing :

Pre-stroke : No. 1 Plunger 1.95 ± 0.05 mm

Note : Adjust with control rod position of mm

Injection order : 1 - 2 - 3 (interval : 120° ± 30°)

Plungers are numbered from the Drive side.

Tappet clearance : Bolt adjustment type ; More than 0.3 mm for all cylinders.
; Shim adjustment type ; Manually rotate the camshaft 2 ~ 3 times and confirm that it rotates smoothly.

4. Injection Quantity :

Adjusting Point	Rod Position (mm)	Pump Speed (r.p.m.)	Injection Q'ty (cc/1000 strokes)	Max. var bet. cyl (%)	Fixed	Remarks
A	8.0	1,350	30.0 ~ 32.0	± 3	Lever	Basic
B	Approx. 5.2	375	5.0 ~ 7.0	± 14	Lever	

5. Timing Advance Specification :

Pump Speed (r.p.m.)						
Advance Angle (deg)						

GOVERNOR ADJUSTMENT

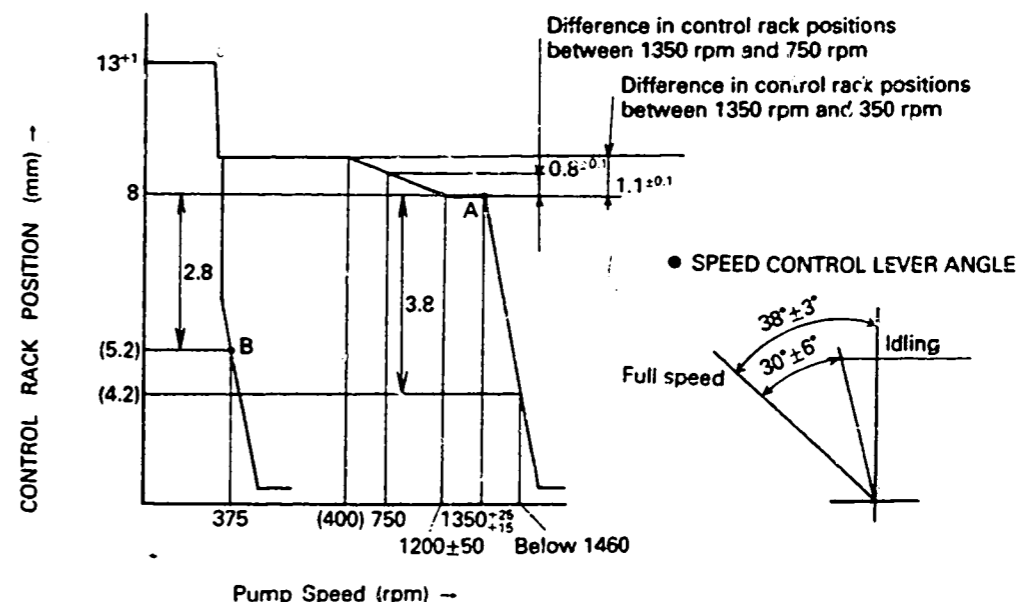

Adjustment

Item	Pump Speed (rpm)	Rack position (mm)	Remarks
Full-load adjustment (temporary)	1350	8.0	• Adjust using screw ①
	1350	8.0	• Confirm injection quantity at point A • Confirm the control lever angle (35° ~ 41°)
Maximum speed adjustment	Fix the control lever in the full-speed position		
	Below 1460 1365 - 1375	(4.2) 8.0	• Confirm • Adjust using screw ②
Idling adjustment	375	(5.2)	• Adjust using idling spring guide
	1250	8.0 13+1	• Confirm injection quantity at point A • Confirm
Stopper bolt adjustment	100	(5.2) - 1	• Adjust using screw ③
Torque Control Spring Adjustment	1350	8.0	• Move the control lever
	750 1150 - 1250	8.7 - 8.9 8.0	• Adjust using screw ④ • Torque control stroke 1 mm is adjusted by shims. • Confirm the torque control stroke is 1.1mm.



DIESEL KIKI CO., LTD. 3-6-7 SHIBUYA, SHIBUYA-KU, TOKYO 150, JAPAN
Service Department Tel. (03) 400-1551 Fax: (03) 499-4115

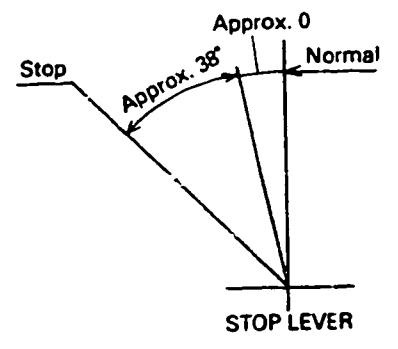
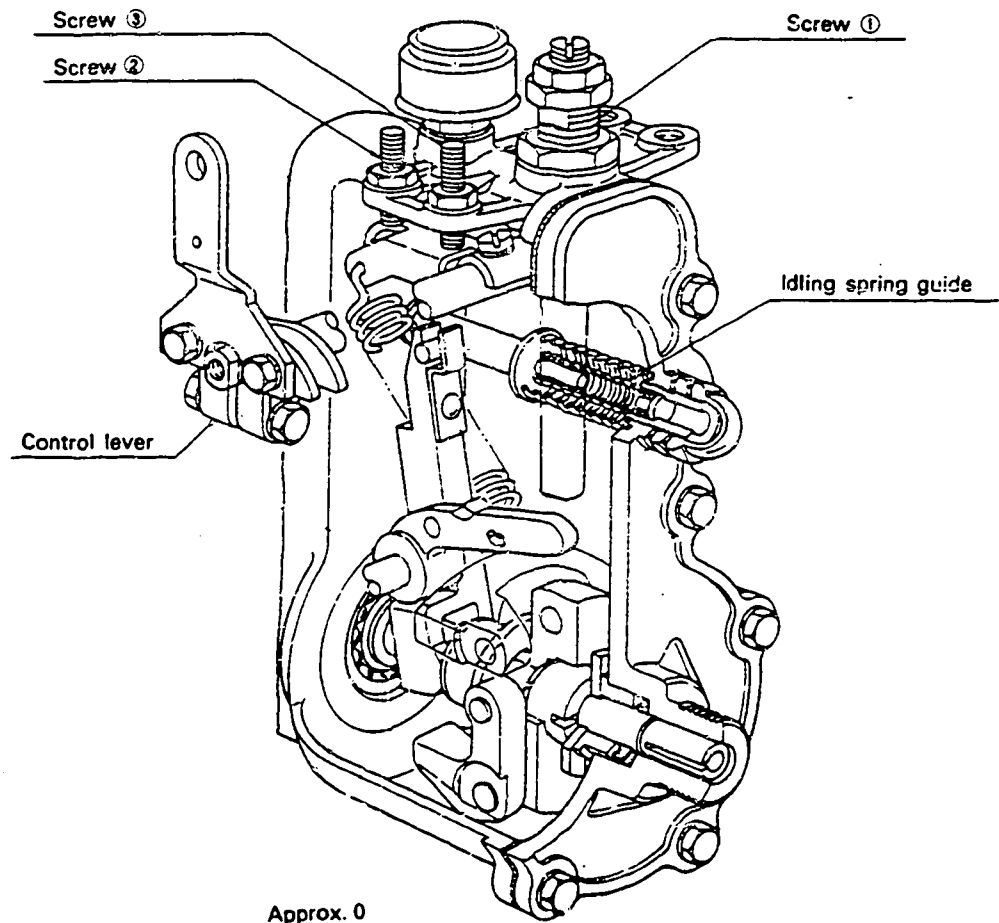

INJ. PUMP CALIBRATION DATA

Distributor-type

TEST OIL:
I S O 4113 or
S A E J967d

ENGINE MODEL : XA

BOSCH No. 9 460 510 410
DKKC No. 104740 - 0132
Date : 28, Feb. 1990 [2]
Company : MAZDA
No. 482513 800A

B - 11

Injection pump No.: 104640-0132 [NP-VE4/10F1500RNP123]

Pump rotation : clockwise-viewed from drive side

For Test Condition see
Microfiche No. WP-210 (N-16)
Spec. A

Pre-stroke : mm

1. Setting	Pump speed (rpm)	Settings	Charge air press (mmHg)	Difference in delivery (cc)
1-1 Timing device travel	1,000	2.4 ~ 2.8 (mm)		
1-2 Supply pump pressure	1,000	4.1 ~ 4.7 (kg/cm ²)		
1-3 Full load delivery without charge air pressure	1,000	46.0 ~ 47.0 (cc/1,000st)		3.0
Full load delivery with charge air pressure		(cc/1,000st)		
1-4 Idle speed regulation	350	4.4 ~ 8.4 (cc/1,000st)		2.0
1-5 Start	100	Above 8.0 (cc/1,000st)		
1-6 Full-load speed regulation	1,650	7.9 ~ 13.9 (cc/1,000st)		4.0
1-7				
1-8				

2. Test Specifications

2-1 Timing device	N = rpm mm	1,000 2.3 ~ 2.9	1,500 4.9 ~ 6.1	
2-2 Supply pump	N = rpm kg/cm ²	500 2.3 ~ 2.9	1,000 4.1 ~ 4.7	1,500 5.9 ~ 6.5
2-3 Overflow delivery	N = rpm cc/10s	1,000 49.0 ~ 93.0		
2-4 Fuel injection quantities				
Speed control lever position	Pump speed (rpm)	Fuel delivery (cc/1,000st)	Charge air press (mmHg)	Difference in delivery (cc)
End stop	1,000	45.5 ~ 47.5		
	500	38.4 ~ 42.4		
	1,500	46.8 ~ 50.8		
	1,650	7.9 ~ 13.9		
	1,750	Below 4.0		
Switch OFF	350	0		
Idling position	350	4.4 ~ 8.4		
	Below 500	0		
2-5 Solenoid	Max. cut-in voltage: 8 V Test voltage: 12 ~ 14 V			

3. Dimensions

K	3.2 ~ 3.4 mm
KF	5.7 ~ 5.9 mm
MS	1.5 ~ 1.7 mm
BCS	— mm
Control lever angle	
α	6 ~ 14 deg
A	4 ~ 10 mm
β	32 ~ 42 deg
B	10.2 ~ 13.7 mm
γ	— deg
C	— mm

DIESEL KIKI

DIESEL KIKI CO. LTD.
Service Department

3-6-7 SHIBUYA, SHIBUYA-KU, TOKYO 150, JAPAN
Tel. (03)6485-4136 · Fax: (03)797-8069

INJ. PUMP CALIBRATION DATA

Distributor-type

TEST OIL:
I S O 4113 or
S A E J967d

ENGINE MODEL : C223

BOSCH No. 9 460 610 419
DKKC No. 104740 - 1023
Date : 28, Feb. 1990
Company : ISUZU
No. 894132 3372

B - 12

Injection pump No.: 104640-1023 [NP-VE4/10F2150RNP25S]

Pump rotation : clockwise-viewed from drive side

For Test Condition see
Microfiche No. WP-210 (N-16)
Spec. A

Pre-stroke : mm

1. Setting		Pump speed (rpm)	Settings	Charge air press (mmHg)	Difference in delivery (cc)
1-1	Timing device travel	1,250	3.5 - 3.9 (mm)	0	
1-2	Supply pump pressure	1,250	4.6 - 5.0 (kg/cm ²)	0	
1-3	Full load delivery without charge air pressure	1,250	47.8 - 48.8 (cc/1,000st)	590 - 610	4.0
	Full load delivery with charge air pressure		(cc/1,000st)		
1-4	Idle speed regulation	375	9.3 - 13.3 (cc/1,000st)	0	2.0
1-5	Start	100	Above 60 (cc/1,000st)	0	
1-6	Full-load speed regulation	2,550	19.9 - 25.9 (cc/1,000st)	590 - 610	7.0
1-7	CSD adjustment	500 - 700	Release speed		
1-8					

2. Test Specifications

2-1	Timing device	N = rpm mm	1,250 3.4 - 4.0	1,700 5.8 - 6.8	2,150 8.7 - 9.4
2-2	Supply pump	N = rpm kg/cm ²	250 1.6 - 2.2	1,250 4.6 - 5.0	2,000 6.1 - 6.7
2-3	Overflow delivery	N = rpm cc/10s	1,000 40.8 - 84.2		
2-4	Fuel injection quantities				
	Speed control lever position	Pump speed (rpm)	Fuel delivery (cc/1,000st)	Charge air press (mmHg)	Difference in delivery (cc)
	End stop	600	34.1 - 39.1	0	
		900	42.7 - 44.7	290 - 310	
		1,150	46.5 - 51.5	590 - 610	
		1,250	34.1 - 39.1	0	
		1,250	47.3 - 49.3	590 - 610	
		2,000	38.4 - 43.4	590 - 610	
		2,175	36.7 - 41.7	590 - 610	
		2,550	19.4 - 26.4	590 - 610	
		2,800	Below 7	590 - 610	
	Switch OFF	375	0	0	
	Idling position	375	9.3 - 13.3	0	
		450	Below 3	0	
	CSD	0 500 - 700	2.3 - 2.7 (Release speed)		
2-5	Solenoid	Max. cut-in voltage: 8 V Test voltage: 12 - 14 V			

3. Dimensions

K	3.2 - 3.4 mm
KF	5.7 - 5.9 mm
MS	1.5 - 1.7 mm
RCS	3.4 - 3.6 mm
Control lever angle	
α	21.0 - 27.0 deg
A	9.2 - 11.0 mm
β	37.0 - 47.0 deg
B	12.0 - 15.0 mm
γ	- deg
C	- mm

DIESEL KIKI

DIESEL KIKI CO. LTD.
Service Department

3-6-7 SHIBUYA, SHIBUYA-KU, TOKYO 150, JAPAN
Tel: (03)5485-4136 · Fax: (03)797-8089

INJ. PUMP CALIBRATION DATA

Distributor-type

TEST OIL:
ISO 4113 or
SAE J967d

ENGINE MODEL : 4D55

BOSCH No. 9 460 610 411
DKKC No. 104740 - 3050
Date : 28, Feb. 1990
Company : MITSUBISHI
No. MD060173

B - 13

Injection pump No.: 104640-3050 [NP-VE4/10F2100RNP148]

Pump rotation : clockwise viewed from drive side

For Test Condition see
Microfiche No. WP-210 (N-16)
Spec. A

Pre-stroke : mm

1. Setting		Pump speed (rpm)	Settings	Charge air press (mmHg)	Difference in delivery (cc)
1-1	Timing device travel	850	1.1 ~ 1.5 (mm)		
1-2	Supply pump pressure	1,250	4.5 ~ 5.1 (kg/cm ²)		
1-3	Full load delivery without charge air pressure	750	33.2 ~ 34.2 (cc/1,000st)		3.0
	Full load delivery with charge air pressure		(cc/1,000st)		
1-4	Idle speed regulation	375	6.9 ~ 9.9 (cc/1,000st)		2.5
1-5	Start	100	66 ~ 86 (cc/1,000st)		
1-6	Full-load speed regulation	2,550	13.1 ~ 19.1 (cc/1,000st)		4.0
1-7					
1-8					

2. Test Specifications

2-1	Timing device	N = rpm mm	850 0.9 ~ 1.7	1,750 6.1 ~ 7.3	2,100 7.8 ~ 8.6
2-2	Supply pump	N = rpm kg/cm ²	600 2.9 ~ 3.5	1,250 4.5 ~ 5.1	2,100 6.5 ~ 7.1
2-3	Overflow delivery	N = rpm cc/10s	1,250 48 ~ 92		
2-4	Fuel injection quantities				
	Speed control lever position	Pump speed (rpm)	Fuel delivery (cc/1,000st)	Charge air press(mmHg)	Difference in delivery (cc)
	End stop	750 1,250 2,100 2,550 2,900	32.7 ~ 34.7 36.7 ~ 40.7 32.2 ~ 36.2 11.1 ~ 21.1 Below 5		
	Switch OFF	375	0		
	Idling position	375 600	6.4 ~ 10.4 Below 3		
2-5	Solenoid	Max. cut-in voltage: 8 V Test voltage: 12 ~ 14 V			

3. Dimensions

K	3.2 ~ 3.4	mm
KF	5.7 ~ 5.9	mm
MS	1.3 ~ 1.5	mm
BCS	—	mm
Control lever angle		
α	55 ~ 63	deg
A		mm
β	38 ~ 48	deg
B		mm
γ	—	deg
C	—	mm

DIESEL KIKI

DIESEL KIKI CO. LTD. 3-6-7 SHIBUYA, SHIBUYA-KU, TOKYO 150, JAPAN
Service Department Tel. (03)5486-4136 Fax: (03)797-4060

INJ. PUMP CALIBRATION DATA

Distributor-type

BOSCH No. 9 460 610 421 1/2
 DKKC No. 104740 - 33P0
 Date : 28. Feb. 1990 (1)
 Company : MITSUBISHI
 No. MD071536

104740 - 3380 2/2

TEST OIL:
 I S O 4113 or
 S A E J967d

ENGINE MODEL : 4D55

Injection pump No.: 104640-3170 [NP-VE4/10F2100RNP172]

Pump rotation : clockwise-viewed from drive side

For Test Condition see
 Microfiche No. WP-210 (N-16)
 Spec. A

Pre-stroke : mm

1. Setting	Pump speed (rpm)	Settings	Charge air press (mmHg)	Difference in delivery (cc)
1-1 Timing device travel	850	1.1 ~ 1.5 (mm)		
1-2 Supply pump pressure	1,250	4.5 ~ 5.1 (kg/cm ²)		
1-3 Full load delivery without charge air pressure	750	33.2 ~ 34.2 (cc/1,000st)		3.0
Full load delivery with charge air pressure		(cc/1,000st)		
1-4 Idle speed regulation	375	6.9 ~ 9.9 (cc/1,000st)		2.5
1-5 Start	100	66 ~ 86 (cc/1,000st)		
1-6 Full-load speed regulation	2,350	6.6 ~ 12.6 (cc/1,000st)		4.0
1-7				
1-8				

2. Test Specifications

2-1 Timing device	N = rpm mm	850 0.9 ~ 1.7	1,750 6.1 ~ 7.3	2,100 7.8 ~ 8.6
2-2 Supply pump	N = rpm kg/cm ²	500 2.9 ~ 3.5	1,250 4.5 ~ 5.1	2,100 6.5 ~ 7.1
2-3 Overflow delivery	N = rpm cc/10s	1,250 48 ~ 92		
2-4 Fuel injection quantities				
Speed control lever position	Pump speed (rpm)	Fuel delivery (cc/1,000st)	Charge air press(mmHg)	Difference in delivery (cc)
End stop	750	32.7 ~ 34.7		
	1,250	36.7 ~ 40.7		
	2,100	32.2 ~ 36.2		
	2,350	5.0 ~ 14.6		
	2,500	Below 5		
Switch OFF	375	0		
Idling position	375	6.4 ~ 10.4		
	600	Below 3		
2-5 Solenoid	Max. cut-in voltage: 8 V Test voltage: 12 ~ 14 V			

3. Dimensions

K	3.2 ~ 3.4 mm
KF	5.7 ~ 5.9 mm
MS	1.3 ~ 1.5 mm
BCS	mm
Control lever angle	
α	55 ~ 63 deg
A	mm
β	38 ~ 48 deg
S	mm
γ	deg
C	mm

B - 14

FICD Mounting Position Adjustment

1. Hold the control lever in the idling position.
2. Adjust the position of the bracket so that the gap between the control lever and the FICD bracket exceeds 1st mm.

DIESEL KIKI

DIESEL KIKI CO., LTD.
 Service Department

3-6-7 SHIBUYA, SHIBUYA-KU, TOKYO 150, JAPAN
 Tel. (03)5485-4135 · Fax: (03)797-8798

INJ. PUMP CALIBRATION DATA

Distributor-type

TEST OIL:
I S O 4113 or
S A E J967d

ENGINE MODEL : SD25

BOSCH No. 9 460 610 400
DKKC No. 104740 - 4622
Date : 28, Feb. 1990
Company : NISSAN DIESEL
No. 16700T 7208

B - 15

Injection pump No.: 104640-4612 [NP-VE4/10F2100RNP327]

Pump rotation : clockwise-viewed from drive side

For Test Condition see
Microfiche No. WP-210 (N-16)
Spec. A

Pre-stroke : 0.26 - 0.3 mm

1. Setting	Pump speed (rpm)	Settings	Charge air press (mmHg)	Difference in delivery (cc)
1-1 Timing device travel	1,000	1.5 - 1.9 (mm)		
1-2 Supply pump pressure	1,000	4.0 - 4.6 (kg/cm ²)		
1-3 Full load delivery without charge air pressure	1,000	37.9 - 38.9 (cc/1,000st)		3.0
Full load delivery with charge air pressure		(cc/1,000st)		
1-4 Idle speed regulation	300	4.5 - 8.5 (cc/1,000st)		2.0
1-5 Start	100	45 - 80 (cc/1,000st)		
1-6 Full-load speed regulation	2,350	11.7 - 17.7 (cc/1,000st)		
1-7				
1-8				

2. Test Specifications:

2-1 Timing device	N = $\frac{1}{2} \pi$ mm	1,000 1.4 - 2.0	1,400 2.7 - 3.9	2,100 5.6 - 6.8
2-2 Supply pump	N = rpm kg/cm ²	600 3.1 - 3.7	1,000 4.0 - 4.6	2,100 6.6 - 7.2
2-3 Overflow delivery	N = rpm cc/10s	1,000 8.0 - 52		
2-4 Fuel injection quantities				
Speed control lever position	Pump speed (rpm)	Fuel delivery (cc/1,000st)	Charge air press (mmHg)	Difference in delivery (cc)
End stop	600	32.8 - 36.8		
	1,000	37.4 - 39.4		
	2,100	34.4 - 38.4		
	2,350	11.2 - 18.2		
	2,450	Below 5		
Switch OFF	300	0		
Idling position	300	4.5 - 8.5		
	350	Below 3		
2-5 Solenoid	Max. cut-in voltage: 8 V Test voltage: 12 - 14 V			

3. Dimensions

K	3.2 - 3.4 mm
KF	5.65 - 5.85 mm
MS	1.1 - 1.3 mm
BCS	- mm
Control lever angle	
α	21.0 - 29.0 deg
A	4.0 - 9.2 mm
β	37.0 - 47.0 deg
B	10.7 - 14.8 mm
γ	deg
C	mm

DIESEL KIKI

DIESEL KIKI CO. LTD. 3-6-7 SHIBUYA, SHIBUYA-KU, TOKYO 150, JAPAN
Service Department Tel. (03)5486-4135 Fax: (03)797-8089

INJ. PUMP CALIBRATION DATA

TEST OIL: ENGINE MODEL : TD25
 ISO 4113 or
 SAE J967d

Injection pump No.: 104640-7180 (NP-VE4/10F2150RNP756)
 Pump rotation : Clockwise-viewed from drive side

BOSCH No. 9 460 610 420 1/3
 DKKC No. 104740-7180
 Date : 28, Feb. 1990 [0]
 Company : MITSUBISHI DIESEL
 No. 105780 84G06

For Test Conditions see
 Microfiche No. VP-210 (N-16)

C - 1

1. Test Conditions

- 1-1 Nozzle : 105780-0000 (NP-DN12SD12T)
- 1-2 Nozzle holder : 105780-2080 (EF8511/9)
- 1-3 Nozzle opening pressure : 150⁺⁵ kg/cm²
- 1-4 Injection pipe : 2 x 6 x 840 mm
- 1-5 Fuel oil temperature : 45⁺⁵ °C
- 1-6 Supply pump pressure : 0.2 kg/cm²

2. Setting	Pump speed (rpm)	Settings	Charge air press (mmHg)	Difference in delivery (cc)
2-1 Timing device travel	1,100	S/T ON: 39 - 47 (mm) OFF: 24 - 28	S/T: Solenoid timer	
2-2 Supply pump pressure	1,100	S/T ON: 45 - 53 (kg/cm ²) OFF: 35 - 41		
2-3 Full load delivery	1,100	48.0 - 49.0 (cc/1,000st)		3.0
2-4 Idle speed regulation	350	4.5 - 8.5 (cc/1,000st)		2.0
2-5 Start	100	45.0 - 80.0 (cc/1,000st)		
2-6 Full-load speed regulation	2,500	10.1 - 14.1 (cc/1,000st)		
2-7 Load-timer Adjustment	1,100	T=1.0 ± 0.2 (mm)		
2-8				
2-9				

3. Test Specifications	Solenoid Timer	ON		OFF	
		N = rpm	mm	1,100	1,700
3-1 Timing device			3.8 - 4.8	2.3 - 2.9	4.3 - 5.5
3-2 Supply pump	N = rpm	1,100	4.5 - 5.3	5.9 - 6.7	1,700
	kg/cm ²				2,150
3-3 Overflow delivery	N = rpm	1,100	43.0 - 87.0	60 - 103	1,100 (without O-ring)
	cc/10s				

3-4 Fuel injection quantities				
Speed control lever position	Pump speed (rpm)	Fuel delivery (cc/1,000st)	Charge air press (mmHg)	Difference in delivery (cc)
Max. speed	1,100	47.5 - 49.5		
	600	45.1 - 49.1		
	2,150	38.5 - 42.7		
	2,300	28.3 - 37.3		
	2,500	9.6 - 14.6		
	2,700	Below 5.0		
	Switch OFF Magnet valve	350	0	
Idling	350	4.5 - 8.5		
	450	Below 3.0		

3-5 Solenoid Max. cut-in voltage: 8V, Test voltage: 12 - 14V

4. Dimensions		
K	3.2 - 3.4	mm
KF	5.7 - 5.9	mm
MS	0.9 - 1.1	mm
BCS	-	mm
Pre-stroke	-	mm
Control lever angle		
α	51.5 - 59.5	deg
A	24.3 - 28.7	mm
β	31.0 - 41.0	deg
B	9.3 - 12.9	mm
γ	-	deg
C	-	mm

- Note
- If there is no designation in the specifications for the Solenoid Timer's ON-OFF position, then the position should be regarded as OFF.

LOAD TIMER ADJUSTMENT

- 1) Adjustment
 - ① Fix the control lever in the position satisfying the following conditions.
 - Boost Pressure : — mmHg
 - Pump Speed : 1,100 rpm
 - Fuel Injection : 38.0 ± 0.5 cc/1000st Quantity
 - ② With the control lever positioned as described in ① above, adjust the governor sleeve so that the Timer Stroke conforms to the specified values (item 2 - 7).

Control lever position			Specified Values	
Pump Speed (rpm)	Fuel Injection Quantity (cc/1000st)	Boost pressure (mmHg)	Timer stroke (mm)	Timer stroke reduction value (mm)
1,100	38.0 ± 1.0	-	-	1.0 ± 0.3
1,100	30.0 ± 1.5	-	-	1.7 ± 0.5

■ Control Lever Angle Measurement Position

- ① Measure the control lever angles (α , β , γ) at hole A.

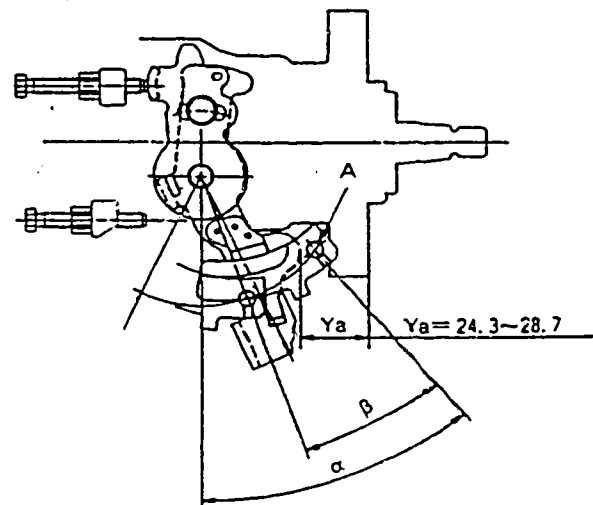

INJ. PUMP CALIBRATION DATA

TEST OIL: IS O 4113 or SAE J967d
ENGINE MODEL : TD25

BOSCH No. 9 460 610 414 1/2
DKKC No. 104740-7210
Date : 28, Feb. 1990
Company : NISSAN DIESEL
No. 16700 30N05

Injection pump No.: 104640-7210 (NP-VE4/10F2150RNP797)
Pump rotation : Clockwise-viewed from drive side

For Test Condition see
Microfiche No. WP-210 (N-16)

1. Test Conditions

- 1-1 Nozzle : 105780-0000 (NP-DN12SD12T)
- 1-2 Nozzle holder : 105780-2080 (EF8511/9)
- 1-3 Nozzle opening pressure : 150^{±5} kg/cm²
- 1-4 Injection pipe : 2 x 6 x 840 mm
- 1-5 Fuel oil temperature : 45^{±5} °C
- 1-6 Supply pump pressure : 0.2 kg/cm²

2. Setting	Pump speed (rpm)	Settings	Charge air press (mmHg)	Difference in delivery (cc)
2-1 Timing device travel	1,100	S/T ON 39 - 47 OFF 24 - 28 (mm)	S/T: Solenoid timer	
2-2 Supply pump pressure	1,100	S/T ON 45 - 53 OFF 35 - 41 (kg/cm ²)		
2-3 Full load delivery	1,100	48.0 - 49.0 (cc/1,000st)		3.0
2-4 Idle speed regulation	350	4.5 - 8.5 (cc/1,000st)		2.0
2-5 Start	100	45.0 - 80.0 (cc/1,000st)		
2-6 Full-load speed regulation	2,500	10.1 - 14.1 (cc/1,000st)		
2-7				
2-8				
2-9				

3. Test Specifications	Solenoid Timer	ON	OFF
3-1 Timing device	N = rpm mm	1,100 3.8 - 4.8	1,100 1,700 2,300 2.3 - 2.9 4.3 - 5.5 6.0 - 7.0
3-2 Supply pump	N = rpm kg/cm ²	1,100 1,700 4.5 - 5.3 5.9 - 6.7	1,100 1,700 2,150 3.5 - 4.1 4.9 - 5.5 5.8 - 6.4
3-3 Overflow delivery	N = rpm cc/10s	1,100 1,100 (without O-ring) 43.0 - 87.0 60 - 103	

3-4 Fuel injection quantities				
Speed control lever position	Pump speed (rpm)	Fuel delivery (cc/1,000st)	Charge air press (mmHg)	Difference in delivery (cc)
Max. speed	1,100	47.5 - 49.5		
	600	45.1 - 49.1		
	2,150	38.5 - 42.8		
	2,300	28.3 - 37.3		
	2,500	9.6 - 14.6		
	2,700	Below 5.0		
Switch OFF Magnet valve	350	0		
Idling	350	4.5 - 8.5		
	450	Below 3.0		
3-5 Solenoid	Max. cut-in voltage: 8V, Test voltage: 12 - 14V			

4. Dimensions	
K	3.2 - 3.4 mm
KF	5.7 - 5.9 mm
MS	0.9 - 1.1 mm
BCS	— mm
Pre-stroke	— mm
Control lever angle	
α	35.5 - 43.5 deg
A	24.3 - 28.7 mm
β	31.0 - 41.0 deg
B	9.3 - 12.9 mm
γ	— deg
C	— mm

Control Lever Angle Measurement Position

- ① Measure the control lever angles (α , β , γ) at hole A.

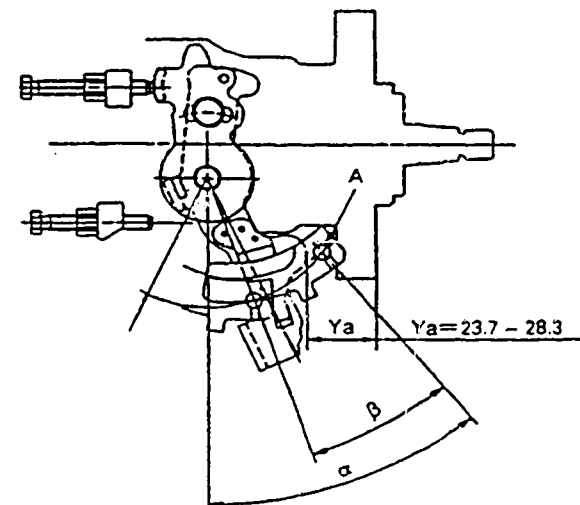

Note

- If there is no designation in the specifications for the Solenoid Timer's ON-OFF position, then the position should be regarded as OFF.

INJ. PUMP CALIBRATION DATA

Distributor-type

TEST OIL:
I S O 4113 or
S A E J967d

ENGINE MODEL : TD27

Injection pump No.: 104540-7350 [NP--VE4/10F2150RNP880]

Pump rotation : clockwise-viewed from drive side

Pre-stroke : mm

BOSCH No. 9 460 610 373 1/4
DKKC No. 104740 - 7350
Date : 28, Feb. 1990
Company : NISSAN DIESEL
No. 16700 24N00

For Test Condition see
Microfiche No. WP-210 (N-16)
Spec. A

C - 4

104740-7350 2/4

1. Setting	Pump speed (rpm)	Settings	Charge air press (mmHg)	Difference in delivery (cc)
1-1 Timing device travel	750	S/T ON: 2.8 - 3.4 (mm) OFF: 1.0 - 1.4	S/T: Solenoid timer	3.0
1-2 Supply pump pressure	750	S/T ON: 3.5 - 4.3 (kg/cm ²) OFF: 2.5 - 3.1		
1-3 Full load delivery without charge air pressure	1,100	51.8 - 52.8 (cc/1,000st)		
Full load delivery with charge air pressure		(cc/1,000st)		
1-4 Idle speed regulation	350	5.3 - 9.3 (cc/1,000st)		2.0
1-5 Start	100	45 - 80 (cc/1,000st)		
1-6 Full-load speed regulation	2,350	31.0 - 35.0 (cc/1,000st)		
1-7 Load-timer Adjustment	1,000	S/T OFF Q=41.0 ± 0.5cc/1,000st T=0.4 ± 0.2 mm		
1-8				

2. Test Specifications	N = rpm	Solenoid Timer									
		ON				OFF					
2-1 Timing device	mm	750	1,100	750	1,100	1,700	2,150	0.9 - 1.5	2.1 - 3.3	4.2 - 5.6	5.5 - 6.8
2-2 Supply pump	kg/cm ²	750	1,100	750	1,100	1,700	2,150	2.5 - 3.1	3.5 - 4.1	4.9 - 5.5	5.8 - 6.4
2-3 Overflow delivery	cc/10s	1,100 (without O-ring)				1,100 (with O-ring)					
		60 - 103				43 - 87					

Speed control lever position	Pump speed (rpm)	Fuel delivery (cc/1,000st)	Charge air press (mmHg)	Difference in delivery (cc)
Max. speed	1,100	51.3 - 53.3		
	600	49.7 - 53.7		
	2,150	43.0 - 47.2		
	2,350	30.5 - 35.5		
	2,550	5.7 - 12.7		
	2,700	Below 5		
Switch OFF Magnet valve	350	0		
Idling position	350	5.3 - 9.3		
	450	Below 3		
2-5 Solenoid	Max. cut-in voltage: 8 V Test voltage: 12 - 14 V			

3. Dimensions	
K	3.2 - 3.4 mm
KE	5.7 - 5.9 mm
MS	0.8 - 1.0 mm
BCS	- mm
Control lever angle	
α	50.0 - 58.0 deg
A	23.7 - 28.3 mm
β	37.0 - 47.0 deg
B	10.7 - 14.8 mm
γ	deg
C	mm

LOAD TIMER ADJUSTMENT

1) Adjustment

① Fix the control lever in the position satisfying the following conditions.

Boost Pressure : - mmHg

Pump Speed : 1,000 rpm

Fuel Injection : 41.0 ± 0.5 cc/1000st
Quantity

② With the control lever positioned as described in ① above, adjust the governor sleeve so that the Timer Stroke conforms to the specified values (item 1 - 7).

Control lever position			Specified Values	
Pump Speed (rpm)	Fuel Injection Quantity (cc/1000st)	Boost pressure (mmHg)	Timer stroke (mm)	Timer stroke reduction value (mm)
1,000	41 ± 1.0	-	-	0.4 ± 0.3
1,000	33 ± 1.5	-	-	0.8 ± 0.5

DIESEL KIKI

DIESEL KIKI CO., LTD.
Service Department

3-6-7 SHIBUYA, SHIBUYA-KU, TOKYO 150, JAPAN
Tel. (03)5485-4135 · Fax: (03)797-8089

■ POTENTIOMETER ADJUSTMENT

Under the following conditions, alter the potentiometer's installation position so that the out-put voltage equals the specified value.

Adjustment Conditions			Specified Value	Remarks
Control lever position	Pump speed (rpm)	Fuel injection quantity (cc/1000st)	Out-put voltage (V)	
Approx. 20.8°	950	Measure	Measure	Adjusting point
Idle	-	-	-	Check point
Full speed	-	-	-	Check point

[In-put Voltage: 10V]

* A control lever position of approximately 20.8°, means that a block gauge of 13.7 mm thickness is inserted between the control lever and the idling stopper bolt.

$$V = (0.1043Q + 3.8379) \pm 0.03 \text{ [V]}$$

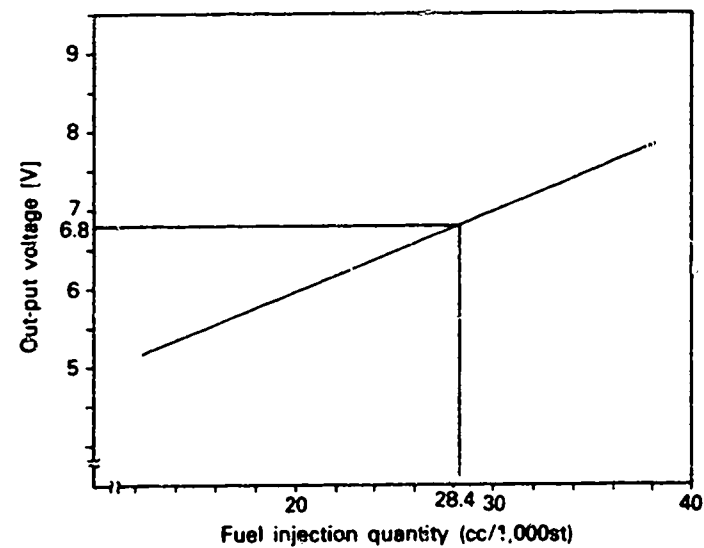

■ Control Lever Angle Measurement Position

- ① Measure the control lever angles (α , β , γ) at hole A.

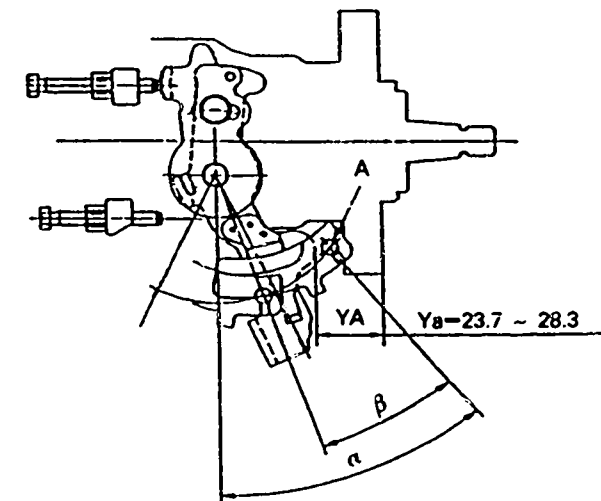

INJ. PUMP CALIBRATION DATA

Distributor-type

BOSCH No. 9 460 610 374 1/2
 DKKC No. 104740 - 8020
 Date : 28, Feb. 1990 (D)
 Company : MITSUBISHI
 No. MD155269

C - 6

104740-8020 2/2

TEST OIL:
 I S O 4113 or
 S A E J967d
 ENGINE MODEL : 4D56

Injection pump No.: 104640-8020 [NP-VE4/10F2100RNP836]

Pump rotation : clockwise-viewed from drive side

For Test Condition see
 Microfiche No. WP-210 (N-16)
 Spec. A

Pre-stroke : mm

1. Setting	Pump speed (rpm)	Settings	Charge air press (mmHg)	Difference in delivery (cc)
1-1 Timing device travel	1,250	4.3 ~ 4.7 (mm)		3.0
1-2 Supply pump pressure	1,250	4.5 ~ 5.1 (kg/cm ²)		
1-3 Full load delivery without charge air pressure	1,250	45.3 ~ 46.3 (cc/1,000st)		
				(cc/1,000st)
1-4 Idle speed regulation	375	8.5 ~ 11.5 (cc/1,000st)		2.0
1-5 Start	100	63 ~ 83 (cc/1,000st)		
1-6 Full-load speed regulation	2,550	15.1 ~ 22.1 (cc/1,000st)		4.0
1-7 Load-timer Adjustment	1,250	T=0.6 ± 0.2 (mm)		
1-8				

2. Test Specifications

2-1 Timing device	N = rpm mm	500 1.6 ~ 2.4	750 2.4 ~ 3.2	1,250 4.2 ~ 4.8	1,750 6.0 ~ 7.2	2,100 7.3 ~ 8.2
2-2 Supply pump	N = rpm kg/cm ²			1,250 4.5 ~ 5.1		2,100 6.5 ~ 7.1
2-3 Overflow delivery	N = rpm cc/10s		1,250 48 ~ 92			

2-4 Fuel injection quantities

Speed control lever position	Pump speed (rpm)	Fuel delivery (cc/1,000st)	Charge air press (mmHg)	Difference in delivery (cc)
Max. speed	1,250	44.8 ~ 46.8		
	600	42.3 ~ 46.3		
	1,750	38.2 ~ 42.2		
	2,100	37.1 ~ 41.3		
	2,550	14.6 ~ 21.6		
	2,900	Below 5		
Switch OFF Magnet valve	375	0		
Idling position	375	8.5 ~ 11.5		
	600	Below 5		
	750	Below 3		

2-5 Solenoid
 Max. cut-in voltage: 8 V
 Test voltage: 12 ~ 14 V

3. Dimensions

K	3.2 ~ 2.7 mm
KF	5.7 ~ 5.9 mm
MS	1.1 ~ 1.3 mm
Full Str.	7.4 ~ 8.2 mm

Control lever angle

α	55 ~ 63 deg
A	10.5 ~ 16.0 mm
β	36 ~ 46 deg
B	10.5 ~ 15.0 mm
γ	— deg
C	— mm

LOAD TIMER ADJUSTMENT

1) Adjustment

① Fix the control lever in the position satisfying the following conditions.

Boost Pressure : — mmHg

Pump Speed : 1,250 rpm

Fuel Injection : 35.7 ± 0.5 cc/1000st
 Quantity

② With the control lever positioned as described in ① above, adjust the governor sleeve so that the Timer Stroke conforms to the specified values (item 1 - 7).

Control lever position			Specified Values	
Pump Speed (rpm)	Fuel Injection Quantity (cc/1000st)	Boost pressure (mmHg)	Timer stroke (mm)	Timer stroke reduction value (mm)
1,250	35.7 ± 1.0	—	—	0.6 ± 0.3
1,250	28.2 ± 1.5	—	—	1.4 ± 0.5

FICD Mounting Position Adjustment

1. Hold the control lever in the idling position.
2. Position the FICD mounting bracket so that the gap between the control lever and the FICD lever is 1.0 mm.

DIESEL KIKI

DIESEL KIKI CO., LTD. 3-6-7 SHIBUYA, SHIBUYA-KU, TOKYO 150, JAPAN
 Service Department Tel. (03)5485-4135 Fax: (03)797-8089

INJ. PUMP CALIBRATION DATA

TEST OH:
ISO 4113 or
SAE J967d

ENGINE MODEL : TD23

DOSCH No. 9 460 610 388 1/2
DKKC No. 104740-9870
Date : 28, Feb. 1990 [1]
Company : NISSAN DIESEL
No. 16700 10T11

Injection pump No.: 104640-9860 [NP-VE4/10F2150RNP58]
Pump rotation : Clockwise-viewed from drive side

For Test Condition see
Microfiche No. WP-210 (N-16)

1. Test Conditions

1-1 Nozzle : 105780-0000 (NP-DN12SD12T) 1-4 Injection pipe : 2 x 6 x 840 mm
1-2 Nozzle holder : 105780-2080 (EF8511/9) 1-5 Fuel oil temp. : 45±0.5 °C
1-3 Nozzle opening pressure : 150±5 kg/cm² 1-6 Supply pump pressure : 0.2 kg/cm²

2. Setting	Pump speed (rpm)	Settings	Charge air press (mmHg)	Difference in delivery (cc)
2-1 Timing device travel	1,100	2.3 - 2.7 (mm)		
2-2 Supply pump pressure	1,100	3.5 - 4.1 (kg/cm ²)		
2-3 Full load delivery	1,100	44.1 - 45.1 (cc/1,000st)		3.0
2-4 Idle speed regulation	350	4.5 - 8.5 (cc/1,000st)		2.0
2-5 Start	100	45.0 - 20.0 (cc/1,000st)		
2-6 Full-load speed regulation	2,300	28.3 - 32.3 (cc/1,000st)		
2-7				
2-8				
2-9				

3. Test Specifications	Solenoid Timer	ON	OFF
3-1 Timing device	N = rpm m:m	1,100 3.7 - 4.7	1,100 1,700 2,550 2.2 - 2.8 4.0 - 5.2 6.4 - 7.4
3-2 Supply pump	N = rpm kg/cm ²		1,100 1,700 2,150 3.5 - 4.1 4.9 - 5.5 5.3 - 6.4
3-3 Overflow delivery	N = rpm cc/10c		1,100 43.0 - 87.0

3-4 Fuel injection quantities	Speed control lever position	Pump speed (rpm)	Fuel delivery (cc/1,000st)	Charge air press (mmHg)	Difference in delivery (cc)
Max. speed		1,100	43.6 - 45.6		
		300	41.5 - 45.5		
		2,150	35.9 - 40.1		
		2,300	27.8 - 32.8		
		2,500	5.4 - 12.4		
		2,700	Below 5.0		
Switch OFF Magnet valve		350	0		
Idling		350 400	4.5 - 8.5 Below 3.0		

3-5 Solenoid Max. cut-in voltage: 8V, Test voltage: 12 - 14V

4. Dimensions

K	3.2 - 3.4	mm
KF	5.7 - 5.9	mm
MS	0.9 - 1.1	mm
BCS	-	mm
Pre-stroke	-	mm
Control lever angle		
α	50.0 - 58.0	deg
A	23.7 - 28.3	mm
β	37.0 - 47.0	deg
B	10.7 - 14.8	mm
γ	-	deg
C	-	mm

C - 7

104740 - 9870 2/2

Control Lever Angle Measurement Position

① Measure the control lever angles (α , β , γ) at hole A.

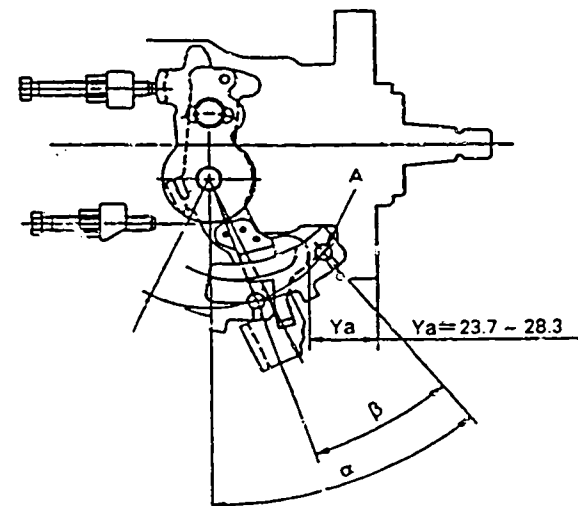

○ Note

■ If there is no designation in the specifications for the Solenoid Timer's ON-OFF position, then the position should be regarded as OFF.

DIESEL KIKI

DIESEL KIKI CO. LTD.

Service Department

3-6-7 SHIBUYA, SHIBUYA-KU, TOKYO 150, JAPAN

Tel. (03)5485-4135 - Fax: (03)787-6089

INJ. PUMP CALIBRATION DATA

C - 8

TEST OIL: ISO 4113 or SAE J967d
ENGINE MODEL : 4JB1-BG

BOSCH No. 9 460 610 409 1/2
DKKC No. 104741-1064
Date : 28, Feb. 1990 [3]
Company : ISUZU
No. 894139 7392

Injection pump No.: 104541-1034 (NP-VE4/11F1900LNP282)
Pump rotation : Counter clockwise-viewed from drive side

For Test Condition see Microfiche No. WP-210 (N-16)

1. Test Conditions

- 1-1 Nozzle : 105780-0000 (NP-DN12SD12T)
- 1-2 Nozzle holder : 105780-2080 (EF8511/9)
- 1-3 Nozzle opening pressure : 150^{±5} kg/cm²
- 1-4 Injection pipe : 2 x 6 x 840 mm
- 1-5 Fuel oil temperature : 45^{±5} °C
- 1-6 Supply pump pressure : 0.2 kg/cm²

2. Setting	Pump speed (rpm)	Settings	Charge air press (mmHg)	Difference in delivery (cc)
2-1 Timing device travel	1,450	1.7 ~ 2.1 (mm)		
2-2 Supply pump pressure	1,450	5.0 ~ 5.4 (kg/cm ²)		
2-3 Full load delivery	1,000	44.1 ~ 45.1 (cc/1,000st)		3.5
2-4 Idling speed regulation	390	6.0 ~ 10.0 (cc/1,000st)		2.0
2-5 Start	100	75 ~ 115 (cc/1,000st)		
2-6 Full-load speed regulation	2,100	17.2 ~ 23.2 (cc/1,000st)		6.0
2-7 ACS adjustment	1,000	Decrease 3.6 ~ 6.2 (cc/1,000st)	-164 ± 5	

3. Test Specifications	Solenoid Timer	ON	OFF
3-1 Timing device	N = rpm mm	460 ~ 660 0.5	1,220 ~ 1,370 0.5
3-2 Supply pump	N = rpm kg/cm ²	1,000 3.0 ~ 3.6	1,450 5.0 ~ 5.4
3-3 Overflow delivery	N = rpm cc/10s	1,450 63 ~ 107	1,950 6.5 ~ 7.1

3-4 Fuel injection quantities				
Speed control lever position	Pump speed (rpm)	Fuel delivery (cc/1,000st)	Charge air press (mmHg)	Difference in delivery (cc)
Max. speed	1,000	43.6 ~ 45.6		
	500	41.2 ~ 49.2		
	700	38.1 ~ 43.1		
	1,450	44.7 ~ 49.7		
	1,800	42.3 ~ 48.3		
	2,000	32.3 ~ 41.3		
	2,100	16.7 ~ 23.7		
	2,300	Below 5.0		
Switch OFF Magnet valve	390	0		
Idling	390	6.0 ~ 10.0		
	550	Below 3.0		
ACS Adjustment	1,000	Decrease 2.9 ~ 6.9	-164 ± 5	

4. Dimensions		
K	2.7 ~ 2.9	mm
KF	4.9 ~ 5.1	mm
MS	0.9 ~ 1.1	mm
BCS	—	mm
Pre-stroke	0.43 ~ 0.47	mm
Control lever angle		
a	14.0 ~ 22.0	deg
A	2.5 ~ 7.6	mm
β	26.0 ~ 36.0	deg
B	7.4 ~ 11.2	mm
γ	—	deg
C	—	mm

3-5 Solenoid Max. cut-in voltage: 8V, Test voltage: 12 ~ 14V

FULL-LOAD FUEL INJECTION QUANTITY AND ACS ADJUSTING PROCEDURE AT HIGH ALTITUDES

1) FULL-LOAD FUEL INJECTION QUANTITY ADJUSTMENT

- ① Remove the ACS cover, the bellows and the adjusting shims.
- ② Perform all adjustments as described in the adjusting specifications, except for ACS adjustment.

2) ACS ADJUSTMENT

- ① Attach the ACS cover, the bellows and the adjusting shims.
- ② At a pump speed of 1000 rpm and referring to the graph below, use the shims to adjust the fuel injection quantity decrease quantity according to the altitude.

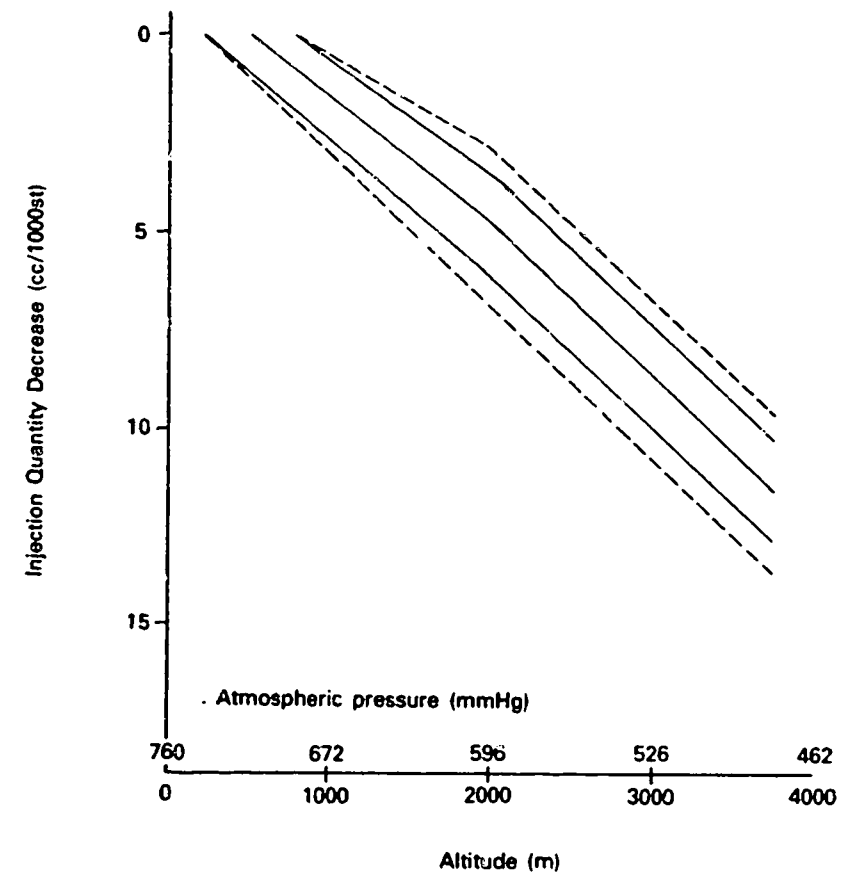

INJ. PUMP CALIBRATION DATA

Distributor-type

TEST OIL:
I S O 4113 or
S A E J967d

ENGINE MODEL : 4JB1 - PK01

BOSCH No. 9 460 610 386

DKKC No. 104741 - 6131

Date : 28, Feb. 1990

Company : ISUZU

No. 894335 7071

C - 9

Injection pump No.: 104641-6131

[NP-VE4/11F1300LNP748]

Pump rotation : Counter clockwise-viewed from drive side

For Test Condition see
Microfiche No. WP-210 (N-16)
Spec. A

Pre-stroke : 0.43 - 0.47 mm

1. Setting	Pump speed (rpm)	Settings	Charge air press (mmHg)	Difference in delivery (cc)
1-1 Timing device travel	1,000	0.5 - 0.9 (mm)		
1-2 Supply pump pressure	1,000	2.1 - 2.5 (kg/cm ²)		
1-3 Full load delivery without charge air pressure	900	39.9 - 40.9 (cc/1,000st)		3.5
Full load delivery with charge air pressure		(cc/1,000st)		
1-4 Idle speed regulation	500	7.6 - 11.6 (cc/1,000st)		2.0
1-5 Start	100	75 - 115 (cc/1,000st)		
1-6 Full-load speed regulation	1,400	18.9 - 24.9 (cc/1,000st)		4.5
1-7				
1-8				

2. Test Specifications

2-1 Timing device	N = rpm mm	1,000 0.4 - 1.0	1,400 1.3 - 1.9
2-2 Supply pump	N = rpm kg/cm ²	500 1.3 - 1.9	1,000 2.1 - 2.5
2-3 Overflow delivery	N = rpm cc/10s	1,000 25 - 68	1,400 2.6 - 3.2
2-4 Fuel injection quantities			
Speed control lever position	Pump speed (rpm)	Fuel delivery (cc/1,000st)	Charge air press (mmHg)
End stop	800	39.4 - 41.4	
	500	41.4 - 49.4	
	1,300	38.0 - 44.0	
	1,400	18.4 - 25.4	
	1,500	Below 5	
Switch OFF	500	0	
Idling position	500	7.6 - 11.6	
	600	Below 3	
2-5 Solenoid	Max. cut-in voltage: 8 V Test voltage: 12 - 14 V		

3. Dimensions

K	2.7 - 2.9 mm
KF	4.9 - 5.1 mm
MS	0.9 - 1.1 mm
BCS	- mm
Control lever angle	
α	8.5 - 16.5 deg
A	mm
β	30.5 - 40.5 deg
B	mm
γ	deg
C	mm

DIESEL KIKI

DIESEL KIKI CO., LTD.

3-6-7 SHIBUYA, SHIBUYA-KU, TOKYO 150, JAPAN

Service Department

Tel. (03)5485-1135 · Fax: (03)797-0089

INJ. PUMP CALIBRATION DATA

1/4

C - 10

104748-2620 2/4

TEST OIL:
ISO 4113 or
SAE J967d

ENGINE MODEL : CD17

BOSCH No. 9 400 61C 408

DKKC No. 104748-2620

Date : 28, Feb. 1990

Company : NISSAN

No. 16700 80A02

Injection pump No.: 104848-2620 (NP-VE4/BF2500LNP739)
Pump rotation : Counter clockwise-viewed from drive side

For Test Condition see
Microfiche No. WP-210 (N-16)

1. Test Conditions

1-1 Nozzle : 105780-0003 (NP-DN12SD12T)	1-4 Injection pipe : 2 x 6 x 840 mm
1-2 Nozzle holder : 105780-2090 (EF8511/9)	1-5 Fuel oil temperature : 45 ^{±3} °C
1-3 Nozzle opening pressure : 150 ^{±1} kg/cm ²	1-6 Supply pump pressure : 0.2 kg/cm ²

2. Setting	Pump speed (rpm)	Settings	Charge air press (mmHg)	Difference in delivery (cc)
2-1 Timing device travel	1,200	1.5 ~ 2.1 (mm)		2.5
2-2 Supply pump pressure	1,200	3.1 ~ 3.7 (kg/cm ²)		
2-3 Full load delivery	1,000	27.1 ~ 28.1 (cc/1,000st)		
2-4 Idle speed regulation	360	3.7 ~ 6.7 (cc/1,000st)		
2-5 Start	100	50.3 ~ 70.3 (cc/1,000st)		
2-6 Full-load speed regulation	2,700	11.8 ~ 17.8 (cc/1,000st)		
2-7				
2-8				
2-9				

3. Test Specifications

3-1 Timing device	N = rpm	1,200	1,800	2,500
	mm	1.4 ~ 2.2	3.5 ~ 4.7	6.9 ~ 7.8
3-2 Supply pump	N = rpm	1,200	1,800	2,500
	kg/cm ²	3.0 ~ 3.8	4.4 ~ 5.2	6.1 ~ 6.9
3-3 Overflow delivery	N = rpm	1,200		
	cc/10s	36.0 ~ 80.0		

3-4 Fuel injection quantities

Speed control lever position	Pump speed (rpm)	Fuel delivery (cc/1,000st)	Charge air press (mmHg)	Difference in delivery (cc)
Max. speed	1,000	26.8 ~ 28.6		
	600	24.8 ~ 28.8		
	2,500	24.3 ~ 28.3		
	2,700	11.3 ~ 18.3		
	2,900	Below 6.0		
Switch OFF Magnet valve	360	0		
Idling	360	3.2 ~ 7.2		2.5
	600	Below 3.0		
Partial load	700	2.2 ~ 11.2		

3-5 Solenoid Max. cut-in voltage: 8V, Test voltage: 12 ~ 14V

4. Dimensions

K	3.2 ~ 3.4	mm
KF	5.7 ~ 5.9	mm
MS	1.7 ~ 1.9	mm
BCS	—	mm
Pre-stroke	—	mm

Control lever angle

α	1.0 ~ -1.0	deg
YA	15.4 ~ 18.1	mm
β	39.0 ~ 49.0	deg
B	11.0 ~ 16.0	mm
γ	13.5 ~ 14.5	deg
C	8.6 ~ 9.2	mm

○ Control Lever Angle Measurement Position

① Measure the control lever angle (α, β, γ) at hole A.

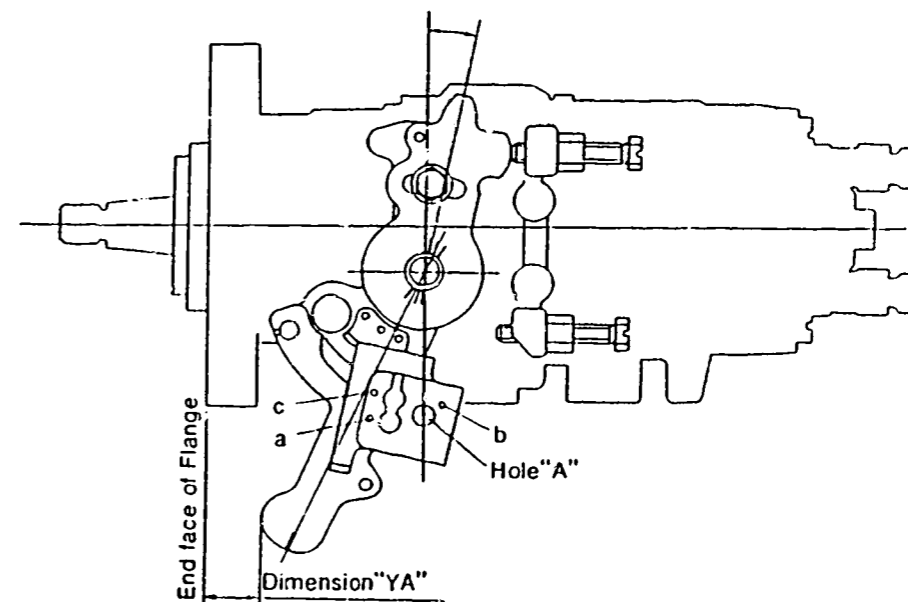

DIESEL KIKI

DIESEL KIKI CO., LTD.

3-6-7 SHIBUYA, SHIBUYA-KU, TOKYO 150, JAPAN

Service Department

Tel. (03)5485-4135 · Fax (03)797-8088

○W-CSD Adjustment

1) Timer stroke adjustment

1. Calculate the timer stroke from Fig. 2 according to the atmospheric temperature at the time of adjustment.
2. Adjust using timer stroke adjusting screw so that the timer stroke is as calculated in Step 1.

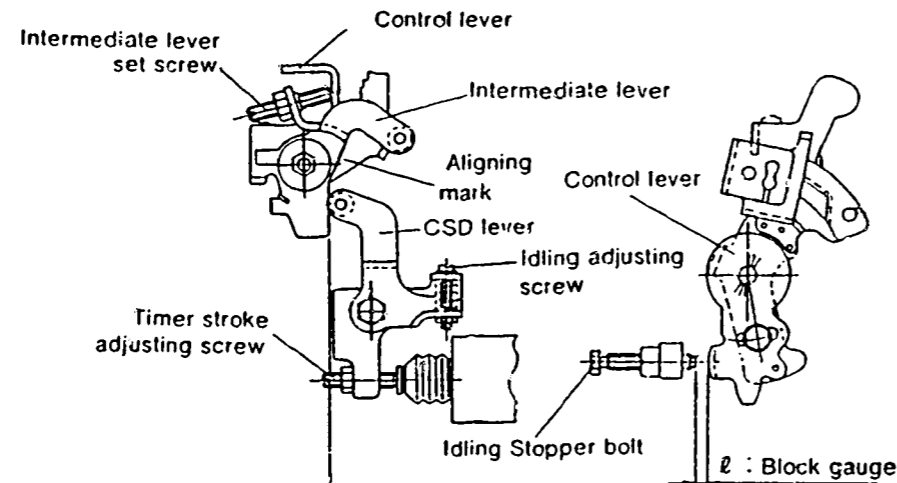

Fig. 1

Formula for calculating Fig. 2 $10 \leq t \leq 20$ $T = -0.027t + 1.09$

Formula for calculating timer stroke: $20 \leq t \leq 40$ $T = -0.0275t + 1.1$

Formula for calculating control lever $t \leq 10$ $l = 6.8$

and idling stopper bolt gap: $10 < t \leq 20$ $l = -0.3t + 9.8$

$20 < t \leq 32$ $l = -0.236t + 8.52$

$32 < t \leq 37$ $l = -0.1936t + 7.1632$

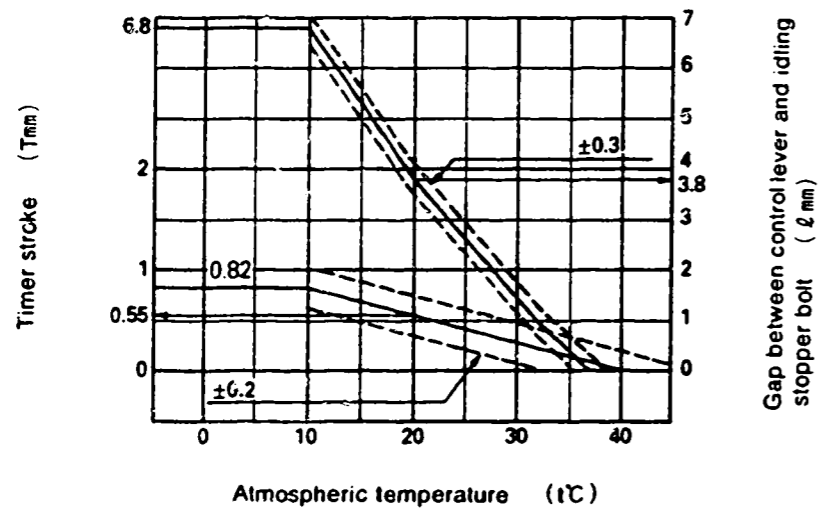

Fig. 2

2) Intermediate lever position adjustment

1. Insert a block gauge (thickness gauge) of 3.8 ± 0.05 mm thickness between the control lever and the idling stopper bolt.
2. Align the intermediate lever with the aligning mark.
3. Adjust the intermediate lever set screw so that the control lever and intermediate lever set screw are in contact, and then fix in position using the locknut.

3) CSD lever adjustment

1. Calculate the block gauge dimension $l \pm 0.05$ mm from Fig 2 according to the atmospheric temperature at the time of adjustment.
2. Insert the block gauge (thickness gauge) selected in Step(1) above between the bracket and the idling stopper bolt.
3. Using the idling bolt, adjust so that the CSD lever roller and intermediate lever are in contact.

Note:

1. The temperature of the wax must be below 30°C when adjusting.
2. When inserting a block gauge (thickness gauge) between the control lever (beacket) and the idling stopper bolt, use the idling adjusting bolt to separate the CSD lever and intermediate lever so that no excessive force is exerted on them.

INJ. PUMP CALIBRATION DATA

Distributor-type

TEST OIL:
I S O 4113 or
S A E J967d

MOTOR : CD17

Injection pump No: 104648 - 2660 [NP-VE4/8F2500LNP717]

Pump rotation : Counter clockwise-viewed from drive side

Pre-stroke : - mm

BOSCH No. 9 460 610 417

DKKC No. 104748 - 2660

Date : 28, Feb. 1990

Company : NISSAN

No. 16700 62M01

For Test Condition see
Microfiche No.WP-210(N16)

Spec. A

C - 12

■ Control Lever Angle Measurement Position

① Measure the control lever angles (α, β, γ) at hole A.

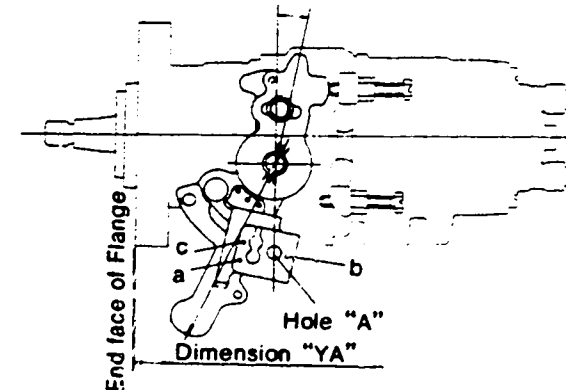

■ Starting Injection Quantity Adjustment

Adjust the starting injection quantity
(item 1/5) using the adjusting bolt
(as shown in the figure at right).

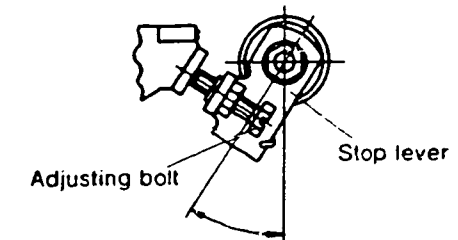

1. Setting	Pump speed (rpm)	Settings	Charge air press(mmHg)	Difference in delivery(cc)
1-1 Timing device travel	1,200	1.5~ 2.1 (mm)		
1-2 Supply pump pressure	1,200	3.1~ 3.7 (kg/cm ²)		
1-3 Full load delivery without charge air pressure	1,000	27.1~28.1 (cc/1,000st)		2.5
Full load delivery with charge air pressure		(cc/1,000st)		
1-4 Idle speed regulation	360	3.7~ 6.7 (cc/1,000st)		
1-5 Start	100	50.3~70.3 (cc/1,000st)		
1-6 Full-load speed regulation	2,700	11.8~17.8 (cc/1,000st)		
1-7				
1-8				

2. Test Specifications

2-1 Timing device	N = rpm	1,200	1,800	2,500
	mm	1.4~ 2.2	3.5~ 4.7	6.9~ 7.8
2-2 Supply pump	N = rpm	1,200	1,800	2,500
	kg/cm ²	3.0~ 3.8	4.4~ 5.2	6.1~ 6.9
2-3 Overflow delivery	N = rpm	1,200		
	cc/10s	36.0~80.0		
2-4 Fuel injection quantities				
Speed control lever position	Pump speed (rpm)	Fuel delivery (cc/1,000st)	Charge air press(mmHg)	Difference in delivery(cc)
Full speed position	1,000	26.6~28.6		
	500	24.8~28.8		
	2,500	24.3~28.3		
	2,700	11.3~18.3		
	2,900	Below 6.0		
Switch OFF	360	0		
Idling position	360	3.2~7.2		2.5
	600	Below 3.0		
Partial load	700	10.8~19.8		
2-5 Solenoid	Max.cut-in voltage : 8 V			
	Test voltage : 12~14 V			

3. Dimensions

K	3.2~3.4	mm
KF	5.7~5.9	mm
MS	1.7~1.9	mm
BCS	-	mm

Control lever angle

α	1.0~-1.0	deg
YA	15.4~18.1	mm
β	39.0~49.0	deg
B	11.0~16.0	mm
γ	13.5~14.5	deg
C	8.6~ 9.2	mm

DIESEL KIKI

DIESEL KIKI CO. LTD.
Service Department

3-6-7 SHIBUYA, SHIBUYA-KU, TOKYO 150 JAPAN
Tel (03) 406-1551 Fax (03) 499-4115

■ POTENTIOMETER ADJUSTMENT

Under the following conditions, after potentiometer installation position so that the out-put voltage equals the specified value.

Adjustment Conditions			Specified Value	Remarks
Control lever position	Pump speed (rpm)	Fuel Injection Quantity(cc/1000st)	Adjustment Value Out-put voltage (V)	
(Approx 14°)	700	measure	measure	Adjusting point
Idle	—	—	—	Check point
Full speed	—	—	—	Check point

{In-put Voltage: 10V}

※ A control lever position of approximately 14° means that a block gauge of 8.9 mm thickness is inserted between the control lever and the idling stopper bolt.

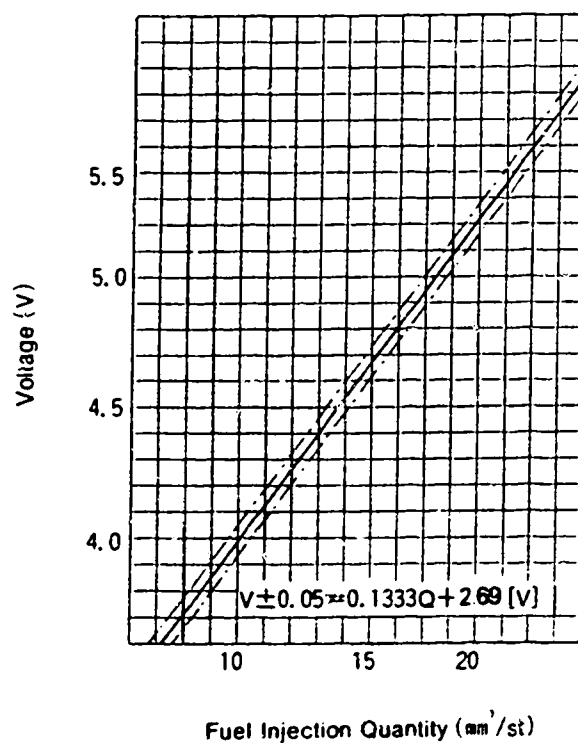

■ W-CSD Adjustment

1) Timer stroke adjustment

1. Calculate the timer stroke from Fig. 2 according to the atmospheric temperature at the time of adjustment.
2. Adjust using timer stroke adjusting screw so that the timer stroke is as calculated in Step 1.

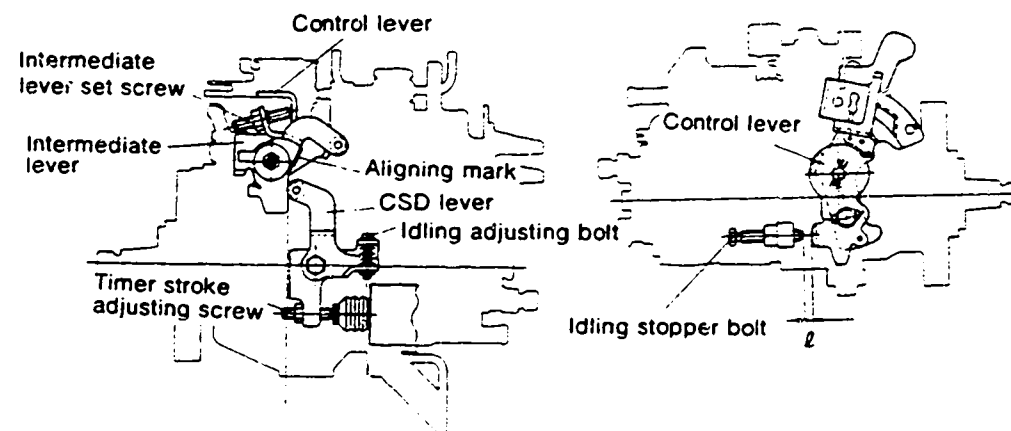

Fig. 1

2) Intermediate lever position adjustment

1. Insert a block gauge (thickness gauge) of 4.1 ± 0.05 mm thickness between the control lever and the idling stopper bolt.
2. Align the intermediate lever with the aligning mark.
3. Adjust the intermediate lever set screw so that the control lever and intermediate lever set screw are in contact, and then fix in position using the locknut.

3) CSD lever adjustment

1. Calculate the block gauge dimension $\ell \pm 0.05\text{mm}$ from Fig. 2 according to the atmospheric temperature at the time of adjustment.
2. Insert the block gauge (thickness gauge) between the control lever and the idling stopper bolt.
3. Using the idling bolt, adjust so that the CSD lever roller and intermediate lever are in contact.

Notes :

1. The temperature of the wax must be below 30°C when adjusting.
2. When inserting a block gauge (thickness gauge) between the control lever (beacket) and the idling stopper bolt, use the idling adjusting bolt to separate the CSD lever and intermediate lever so that no excessive force is exerted on them.

Formula for calculating Fig. 2

Formula for calculating timer stroke:

$$\text{When } 10 \leq t \leq 20 \quad T = -0.027t + 1.09$$

$$\text{When } 20 \leq t \leq 40 \quad T = -0.0275t + 1.1$$

Formula for calculating control lever and idling stopper bolt gap:

$$\text{When } t \leq 10 \quad \ell = 4.6$$

$$\text{When } 10 < t \leq 20 \quad \ell = -0.17t + 6.3$$

$$\text{When } 20 < t \leq 28.5 \quad \ell = -0.235t + 7.6$$

$$\text{When } 28.5 < t \leq 36 \quad \ell = -0.12t + 4.32$$

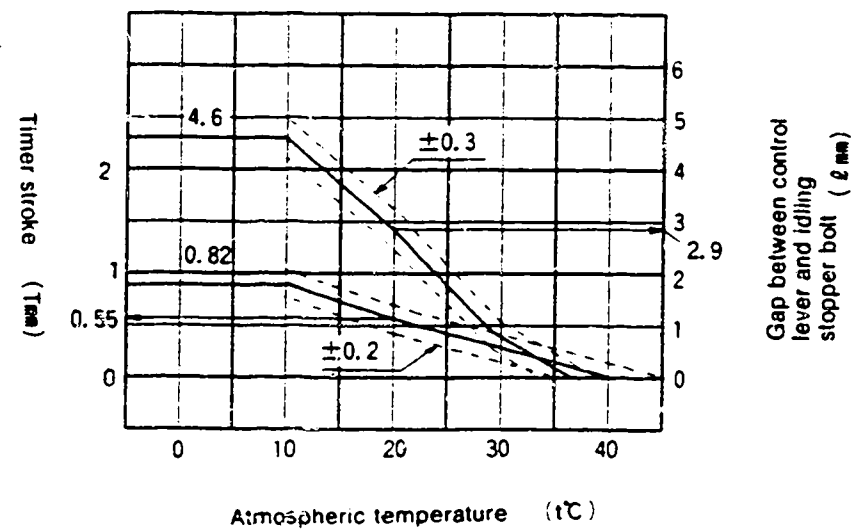

Atmospheric temperature (t°C)

Fig. 2

INJ. PUMP CALIBRATION DATA

TEST OIL:
ISO 4113 or
SAE J967d

ENGINE MODEL : LD20(VCI)

BOSCH No. 9 460 610 426 1/3
DKKC No. 104749 - 2313
Date : 28. Feb. 1990 [3]
Company : NISSAN
No. 1670014CE1

For Test Condition see
Microfiche No. WP-210 (N-16)

Injection pump No.: 104649-2311 (NP-VE4/DF2300RNP454)
Pump rotation : Clockwise-viewed from drive side

C - 15

104749 - 2313 2/3

1. Test Conditions

1-1 Nozzle : 105780-0000 (NP-DN12SD12T)	1-4 Injection pipe : 2 x 6 x 840 mm
1-2 Nozzle holder : 105780-2080 (EF8511/9)	1-5 Fuel oil temperature : 45 [±] °C
1-3 Nozzle opening pressure : 150 [±] kg/cm ²	1-6 Supply pump pressure : 0.2 kg/cm ²

2. Setting

Setting	Pump speed (rpm)	Settings	Charge air press (mmHg)	Difference in delivery (cc)
2-1 Timing device travel	900	1.3 - 1.7 (mm)		2.5
2-2 Supply pump pressure	900	3.2 - 3.8 (kg/cm ²)		
2-3 Full load delivery	2,300	29.5 - 30.5 (cc/1,000st)		
Full load delivery		(cc/1,000st)		
2-4 Idle speed regulation	350	4.7 - 7.7 (cc/1,000st)		
2-5 Start	100	40.0 - 50.0 (cc/1,000st)		
2-6 Full-load speed regulation	2,600	10.6 - 16.6 (cc/1,000st)		
2-7 Load-timer adjustment	900	0.65 ± 0.2 (mm)		
2-8				
2-9				

3. Test Specifications

3-1 Timing device	N = rpm	900	1,800	2,300
	mm	1.2 - 1.8	5.5 - 6.7	7.7 - 8.9
3-2 Supply pump	N = rpm	900	1,800	2,125
	kg/cm ²	3.1 - 3.9	5.1 - 5.9	7.3 - 7.9
3-3 Overflow delivery	N = rpm	900		
	cc/10s	35 - 79		

3-4 Fuel injection quantities

Speed control lever position	Pump speed (rpm)	Fuel delivery (cc/1,000st)	Charge air press (mmHg)	Difference in delivery (cc)
Max. speed	1,800	28.4 - 32.8		
	2,300	29.0 - 33.0		
	2,600	10.1 - 17.1		
	2,700	Below 6.0		
Switch OFF Magnet valve	350	0		
Idling	350	4.2 - 8.2		2.5
	450	Below 3.0		
Partial load	900	4.1 - 14.1		

4. Dimensions

K	3.2 - 3.4	mm
KF	5.7 - 5.9	mm
MS	1.1 - 1.3	mm
BCS	-	mm
Pre-stroke	-	mm

Control lever angle

α	21 - 29	deg
A	(4.3 - 9.6)	mm
β	36 - 46	deg
B	(10.9 - 14.6)	mm
γ	10.5 - 11.5	deg
C	(6.9 - 7.5)	mm

LOAD TIMER ADJUSTMENT

1) Adjustment

① Fix the control lever in the position satisfying the following conditions.

Boost Pressure : - mmHg

Pump Speed : 900 rpm

Fuel Injection : 17 ± 1 cc/1000st
Quantity

② With the control lever positioned as described in ① above, adjust the governor sleeve so that the Timer Stroke conforms to the specified values (2 - 7).

2) Confirmation of Timer Characteristics

Fix the control lever in the position satisfying the following conditions, and confirm the Timer Stroke.

Control lever position			Specified Values	
Pump Speed (rpm)	Fuel Injection Quantity (cc/1000st)	Boost pressure (mmHg)	Timer stroke (mm)	Timer stroke reduction value (mm)
900	17.0 ± 1.5	-		0.65 ± 0.3
900	10.0 ± 1.5	-		1.2 ± 0.5

DIESEL KIKI

DIESEL KIKI CO. LTD.
Service Department

3-6-7 SHIBUYA, SHIBUYA-KU, TOKYO 150, JAPAN
Tel: (03)5485-4136 · Fax: (03)797-8088

■ M—CSD Adjustment

- 1) Fix the intermediate lever adjustment screw in position (adjust with the M—CSD released)
 1. Hold the control lever (3) in the idling position.
 2. Move the adjusting screw to a horizontal position.
 3. Adjust using the adjusting screw (1) so that the gap between the control lever (3) and the adjusting screw (1) is 1 – 2 mm, and then fix the screw using the nut.
- 2) Fixing the M—CSD Stopper (9)
 1. Turn the drive shaft slowly and fix the drive shaft in a position where a load is applied (the point where the roller in the roller holder contacts the cam surface of the cam disc).
 2. Move the CSD lever (6) to the advance side.
 3. Fix the CSD lever in the position where the ball pin at the tip of the shaft lightly contacts the roller holder (roller holder advance angle "0").
 4. Move the CSD lever to the advance side.
 5. Then, adjust the position of the stopper (9) so that the timer stroke is 1.23 ± 0.2 mm and fix the stopper (9) using the screw (10).
- 3) Screw (7) Adjustment
 1. Fix the control lever in the idling position.
 2. Move the CSD lever to the advance side.
 3. Then, adjust the screw (7) so that the clearance between the control lever and the idling stopper bolt is 7.2 ± 0.5 mm, and fix the screw (7) using the nut (8).

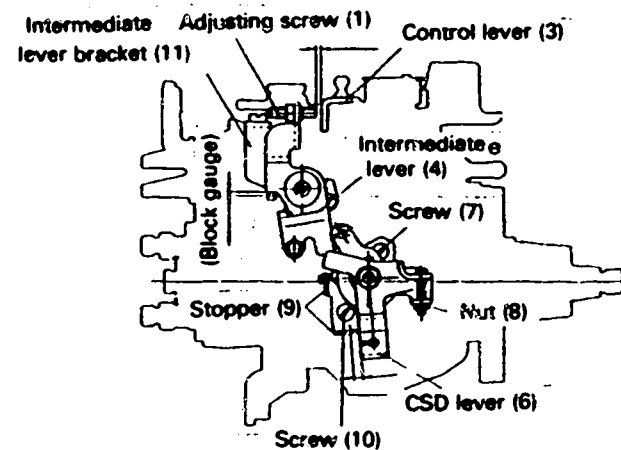

INJ. PUMP CALIBRATION DATA

ENGINE MODEL S6D155

BOSCH No. 9 400 610 113 1/4
 DKKC No. 106672 - 4332
 Date : 28, Feb. 1990 [T]
 Company : KOMATSU
 No. 6127711033

D - 1

106672-4332 2/4

Injection pump : PES6PD Governor : EP/RSUV Timing device :
 106067-8161 105448-9282

1. Test Conditions :

Pump rotation : clockwiseviewed from drive side

Nozzle & Nozzle Holder Ass'y : 105780-0050 Nozzle Holder : 105780-2090
 (BOSCH Type No. DN37D112N211) (BOSCH Type No. EFEP215)

Nozzle opening pressure : 175 kg/cm² Transfer pump pressure : 1.6 kg/cm²

Injection pipe :
 Inner Dia. 2 mm x Outer Dia. 6 mm — Length 600 mm

Test Oil : ISO4113 or SAE Standard Test Oil (SAE J957d) Oil Temp. : 40±5°C

Overflow valve opening pressure : — kg/cm²

2. Injection Timing :

Pre-stroke : No. 1 Plunger — mm

Note : Adjust with control rod position of mm

Injection order : 1 - 5 - 3 - 6 - 2 - 4 (interval : 60° ± 30°)

Plungers are numbered from the Drive side.

Tapet clearance : Bolt adjustment type : More than 0.3 mm for all cylinders.
 Shim adjustment type : Manually rotate the camshaft 2 ~ 3 times and confirm that it rotates smoothly.

4. Injection Quantity :

Adjusting Point	Rod Position (mm)	Pump Speed (r.p.m.)	Injection Q'ty (cc/1000 strokes)	Max. var bet. cyl (%)	Fixed	Remarks
A	14.3	1,000	245 ~ 255	—	Rack	Basic
B	8.6	300	25 ~ 31	± 10	Rack	
C	14.9	700	270 ~ 280	—	Lever	

5. Timing Advance Specification :

Pump Speed (r.p.m)	Advance Angle (deg)					

3. GOVERNOR ADJUSTMENT

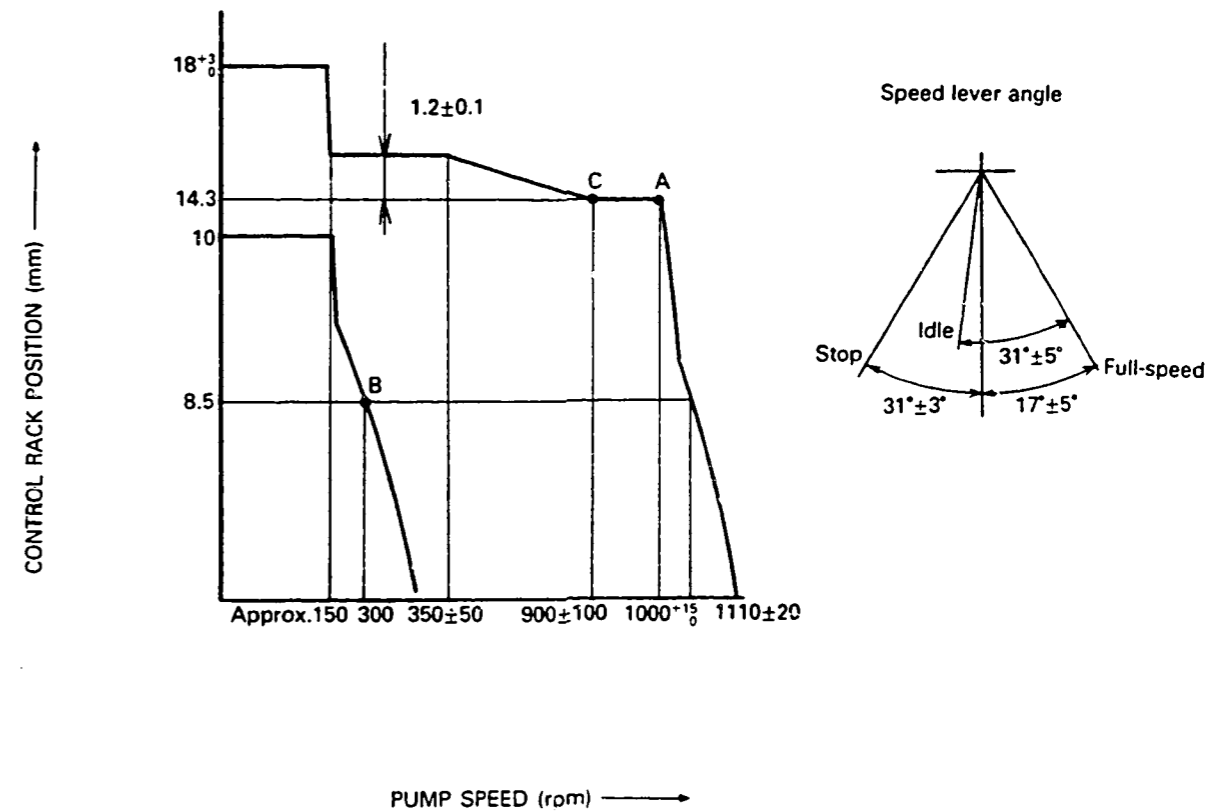

Note

- Before adjustment, remove the idling sub spring and the torque control spring.
- Move the control lever fully in the stop direction, and set the minimum-speed stopper bolt so that the control rack position is 0.5 ~ 1.0 mm.

Adjustment

Item	Pump Speed (rpm)	Rack Position (mm)	Remarks
Full-load Adjustment (Temporary)	1000 ~ 1015	14.3	• Adjust using screw ①
	1000	14.3	• Adjust using screw ②
Torque Control Spring Adjustment	300	13.2 ~ 15.6	• Adjust using spring capsule ①
	300 ~ 400	13.2 ~ 15.6	• Confirm
	700	Approx. 14.9	• Confirm
	Approx. 900	14.3	• Confirm the torque control stroke is 1.2±0.1 mm.



DIESEL KIKI CO. LTD.
 Service Department

3-6-7 SHIBUYA, SHIBUYA-KU, TOKYO 150, JAPAN
 Tel. (03) 400-1551 - Fax: (03) 499-4115

Item	Pump Speed (rpm)	Rack Position (mm)	Remarks
Idling Adjustment	0 300 —	10.0 8.6 —	<ul style="list-style-type: none"> • Fix the control lever • Adjust using spring capsule ② • Confirm
Maximum-speed Adjustment	1000 - 1015 1080 - 1130	14.3 8.6	<ul style="list-style-type: none"> • Adjust using screw ① • Confirm speed droop • Confirm • Confirm
Full-load Adjustment (Install the cover on governor cover)	1000	14.3	<ul style="list-style-type: none"> • Adjust using screw ③
Control Lever Angle Measurement	<ul style="list-style-type: none"> • Measure the control lever angle at the "idling" and "full" positions. • When the control lever is depressed toward the "full" position, replace the shifter's shim with a thicker one. • When the control lever is depressed toward the "idling" position, replace the shifter's shim with a thinner one. 		

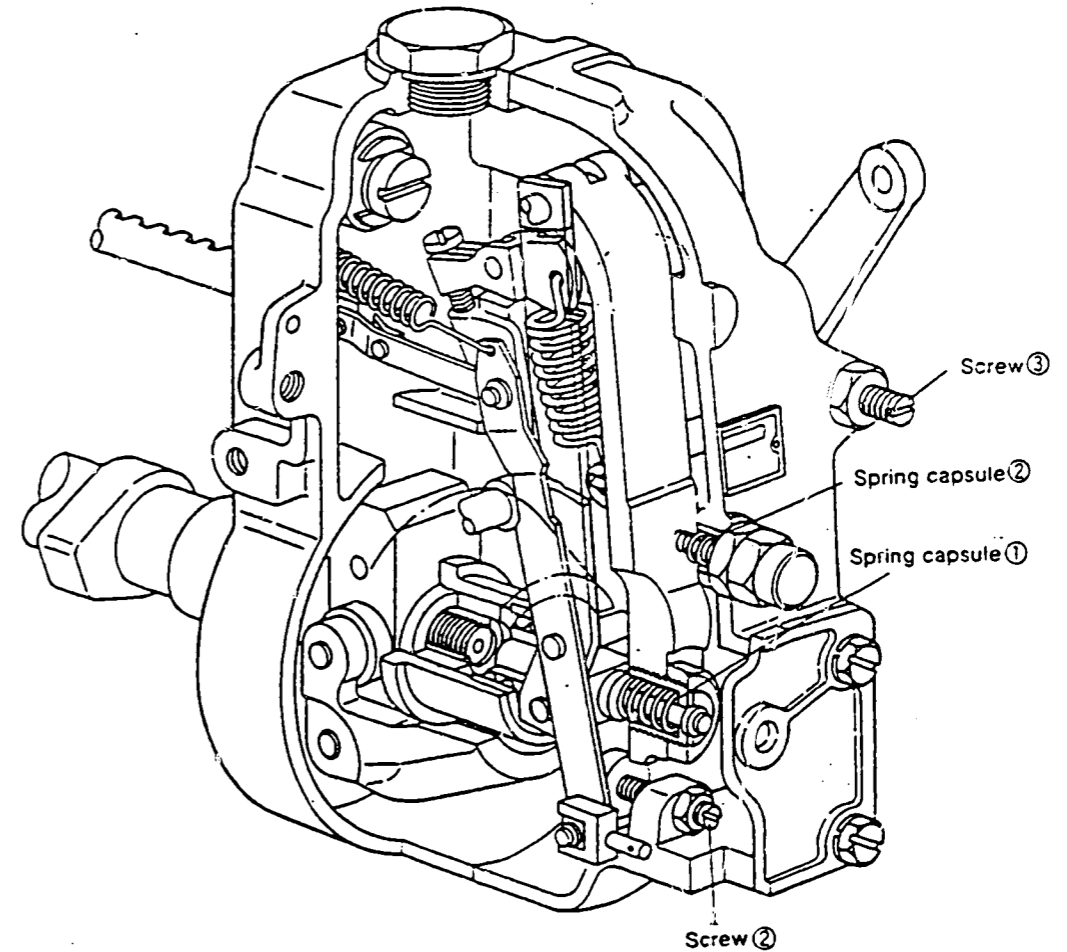



GENERAL
October, 1988
D.R.P. 013 1/4

N - 14

GENERAL
October, 1988
D.R.P. 013 2/4

Service Information

NOZZLES AND NOZZLE HOLDERS FOR INJECTION PUMP ADJUSTMENT

Nozzles and nozzle holders with new specifications are now available, in addition to the nozzles and nozzle holders for injection pump adjustment published in the recent Service Information bulletins (S.I. 180, 189 and 196), bringing the total number of test conditions to eleven.

This Service Information lists the new calibration specifications.

When adjusting injection pumps, refer to the test conditions table in the calibration data when preparing the test nozzles, nozzle holders and test lines.

Note : This Service Information is an addition to the previously published Service Information No S.I. 198, and contains the nozzles, nozzle holders and test lines.

Nozzle and nozzle holder ass'y

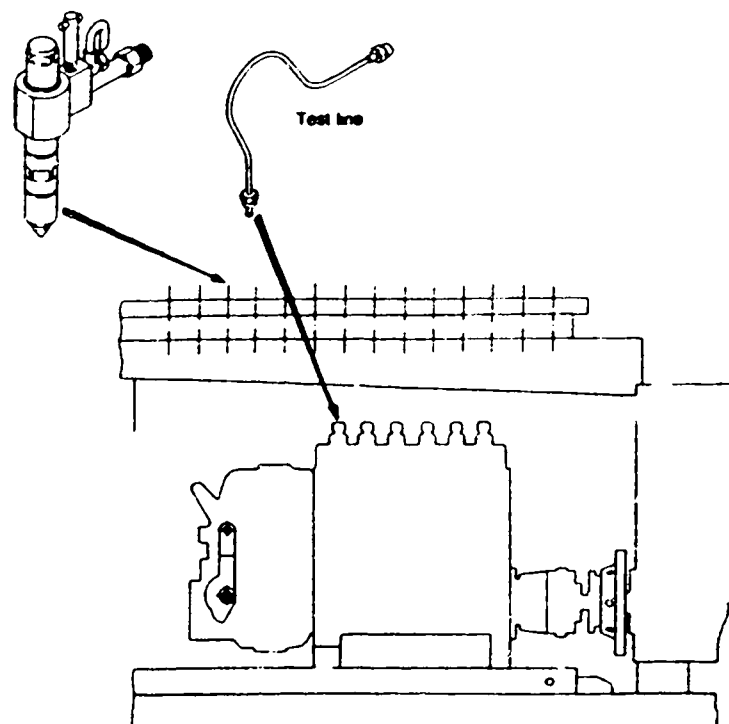

Pump Model	PFR · KD, KX, MD	VM	VE (Current Spec.)	VE (New Spec.)
N. & N.H. Ass'y Bosch No.	105780-8180	105780-8080	105780-8140 (NP-EF8511/9A) 1 688 901 000	105780-8190 1 688 901 022
N. Holder Ass'y Bosch No.	105780-2140	105780-2010 (NP-EF8511NP1)	105780-2080 (NP-EF8511/9) 1 688 901 013	105780-2150
Nozzle Ass'y Bosch No.	105780-0000 (NP-DN12SD12T) 0 681 443 014	105780-0000 (NP-DN12SD12T) 0 681 443 014	105780-0000 (NP-DN12SD12T) 0 681 443 014	105780-0060 (NP-DN0SD15:0) 1 688 901 992
Nozzle Opening Pressure (kg/cm ²)	120 ± 5	150 ± 5	150 ± 5	133 ± 3
Test Line Bosch No.	157805-3320 φ2mm x φ6mm x 600mm M14 x 1.5 - M12 x 1.5 1 680 750 014	157805-0320 φ2mm x φ6mm x 840mm M14 x 1.5 - M12 x 1.5 1 680 750 017	157805-0321 φ2mm x φ6mm x 640mm M14 x 1.5 - M12 x 1.5 1 680 750 017	157805-7320 φ2mm x φ6mm x 450mm M14 x 1.5 - M12 x 1.5 1 680 750 073
Test Line Bosch No.		157805-2720 φ2mm x φ6mm x 840mm M14 x 1.5 - M14 x 1.5		
Joint Ass'y Bosch No.				157641-4720 (For 1 to 6 cylinders) KDEP 1140
Tube Ass'y Bosch No.				157641-4020 KDEP 1140
			KIT NO. BOSCH NO.	105766-1350

DIESEL KIKI CO., LTD.

Service Dept.

Printed in Japan

N - 15

GENERAL
October, 1988
D.R.P. 013 3/4

GENERAL
October, 1988
D.R.P. 013 4/4

Test conditions

Pump Model	PES · K	PE · A (D)	PE · A W/OACT & W/OSE	PE · P (Q ≤ 200 mm ³ /st.)
N. & N.H. Ass'y Bosch No.	105780-8140 (NP - EF8511/9A) 0 681 343 009	105780-8140 (NP - EF8511/9A) 0 681 343 009	105780-8190 1 688 901 022	105780-8140 (NP - EF8511/9A) 0 681 343 009
N. & N.H. Ass'y Bosch No.	105780-2080 (NP - EF8511/9) 1 688 901 013	105780-2080 (NP - EF8511/9) 1 688 901 013	105780-2150	105780-2080 (NP - EF8511/9) 1 688 901 013
N. & N.H. Ass'y Bosch No.	105780-0000 (NP - DN12SD12T) 0 681 443 014	105780-0000 (NP - DN12SD12T) 0 681 443 014	105780-0080 (NP - DN6SD1510) 1 688 901 992	105780-0000 (NP - DN12SD12T) 0 681 443 014
Nozzle Opening Pressure (kg/cm ²)	175 + 5	175 + 5	133 + 3	175 + 5
Test Line Bosch No.	157805-3320 φ2mm x φ6mm x 600mm M14 x 1.5 - M12 x 1.5 1 680 750 014	157805-3320 φ2mm x φ6mm x 600mm M14 x 1.5 - M12 x 1.5 1 680 750 014	157805-3320 φ2mm x φ8mm x 600mm M14 x 1.5 - M12 x 1.5 1 680 750 014	157805-4720 φ3mm x φ8mm x 600mm M14 x 1.5 - M14 x 1.5 1 680 750 015
Test Line Bosch No.	157805-0620 φ2mm x φ6mm x 600mm M14 x 1.5 - M14 x 1.5 1 680 750 008	157805-0620 φ2mm x φ6mm x 600mm M14 x 1.5 - M14 x 1.5 1 680 750 008	---	---

Test conditions

Pump Model	PE · P, PD (Q > 200 mm ³ /st.)	PE · P - S7S (FOR KOMATSU SA6D170B)	PE · ZWX, ZWY
N. & N.H. Ass'y Bosch No.	105780-3130 (NP - EFEP215A) 0 681 443 022	105780-8130 (NP - EFEP215A) 0 681 443 022	105780-8130 (NP - EFEP215A) 0 681 443 022
N. Holder Ass'y Bosch No.	105780-2090 (NP - EFEP215) 0 681 343 002	105780-2090 (NP - EFEP215) 0 681 343 002	105780-2090 (NP - EFEP215) 0 681 343 002
Nozzle Ass'y Bosch No.	105780-0050 (NP - DN6TD119NP1T) 0 681 443 021	105780-0050 (NP - DN6TD119NP1T) 0 681 443 021	105780-0050 (NP - DN6TD119NP1T) 0 681 443 021
Nozzle Opening Pressure (kg/cm ²)	175 + 5	175 + 5	175 + 5
Test Line Bosch No.	157805-5420 φ2mm x φ8mm x 600mm M18 x 1.5 - M14 x 1.5 1 680 750 026	157805-7520 φ4mm x φ8mm x 1000mm M18 x 1.5 - M14 x 1.5 1 680 750 008	157805-2020 φ4mm x φ8mm x 1500mm M18 x 1.5 - M18 x 1.5 1 680 750 027

Table of Contents (DKKC No. → BOSCH No.)

Table of Contents (BOSCH No. → DKKC No.)

DKKC No.	BOSCH No.	Location	DKKC No.	BOSCH No.	Location	BOSCH No.	DKKC No.	Location	BOSCH No.	DKKC No.	Location
101431-0620	9 400 610 114	WP-220 B- 1 - B- 2				9 400 610 102	101692-2540	WP-220 B- 7 - B- 8			
101602-0640	9 400 610 106	WP-220 B- 3 - B- 4				9 400 610 106	101602-0640	WP-220 B- 3 - B- 4			
101631-9280	9 400 610 108	WP-220 B- 5 - B- 6				9 400 610 108	101631-9280	WP-220 B- 5 - B- 6			
101692-2540	9 400 610 102	WP-220 B- 7 - B- 8				9 400 610 112	104303-2511	WP-220 B- 9 - B-10			
104303-2511	9 400 610 112	WP-220 B- 9 - B-10				9 400 610 113	108672-4332	WP-220 D- 1 - D- 2			
104740-0130	9 460 610 410	WP-220 B-11				9 400 610 114	101431-0620	WP-220 B- 1 - B- 2			
104740-1023	9 460 610 419	WP-220 B-12				9 460 610 373	104740-7250	WP-220 C- 4 - C- 5			
104740-3050	9 460 610 411	WP-220 B-13				9 460 610 374	104740-8020	WP-220 C- 6			
104740-3380	9 460 610 421	WP-220 B-14				9 460 610 386	104741-6131	WP-220 C- 9			
104740-4622	9 460 610 400	WP-220 B-15				9 460 610 388	104740-9870	WP-220 C- 7			
104740-7180	9 460 610 420	WP-220 C- 1 - C- 2				9 460 610 400	104740-4622	WP-220 B-15			
104740-7210	9 460 610 414	WP-220 C- 3				9 460 610 408	104746-2620	WP-220 C-10 - C-11			
104740-7350	9 460 610 373	WP-220 C- 4 - C- 5				9 460 610 409	104741-1064	WP-220 C- 8			
104740-8020	9 460 610 374	WP-220 C- 6				9 460 610 410	104740-0130	WP-220 B-11			
104740-9870	9 460 610 388	WP-220 C- 7				9 460 610 411	104740-3050	WP-220 B-13			
104741-1064	9 460 610 409	WP-220 C- 8				9 460 610 414	104740-7210	WP-220 C- 3			
104741-6131	9 460 610 386	WP-220 C- 9				9 460 610 417	104748-2660	WP-220 C-12 - C-14			
104746-2620	9 460 610 408	WP-220 C-10 - C-11				9 460 610 419	104740-1023	WP-220 B-12			
104748-2660	9 460 610 417	WP-220 C-12 - C-14				9 460 610 420	104740-7180	WP-220 C- 1 - C- 2			
104749-2313	9 460 610 426	WP-220 C-15 - C-16				9 460 610 421	104740-3380	WP-220 B-14			
108672-4332	9 400 610 113	WP-220 D- 1 - D- 2				9 460 610 426	104749-2313	WP-220 C-15 - C-16			